

41 BLANC	52 LILAS
42 GRIS	53 ROI
43 NOIR	54 BLEUET
44 JONQUILLE	55 CIEL
45 BANANE	56 SANITAIRE
46 OCRE	57 JAVA
47 ROSE	58 KIWI
48 CLÉMENTINE	59 GAZON
49 COQUELICOT	60 CELADON
50 FRAMBOISE	61 CRÈME
51 IRIS	62 MARRON
NEW	30 CHERRY
31 SMOKE	32 ANTHRACITE



www.ecopostural.com

Horario: De lunes a viernes de 08:00 h. - 14:00 h. / de 15:00 h. - 18:30 h.
 Dirección: Avda. Enrique Gimeno, 27 · 12006 Castellón (España)
 Tels.: ES (+34) 964 50 30 21 FR (+34) 964 25 58 06
 UK (+34) 964 20 01 53 DE (+34) 964 25 58 09
 Fax: (+34) 964 50 34 10
 info@ecopostural.com · www.ecopostural.com



CATÁLOGO
 2018 · 2019
 www.ecopostural.com

2018 · 2019

Colores disponibles · Couleurs disponibles · Available colours · Verfügbare Farben
 La reproducción fotográfica puede no ser totalmente exacta a la tonalidad de los colores naturales.
 La reproduction photographique des couleurs peut ne pas être exacte à la couleur réelle des produits.
 The photographic featuring of colours may not be totally accurate.
 Die fotografische Abbildung kann von dem normalen Farbton etwas abweichen.



ecopostural
mobiliario para la salud.

CATÁLOGO 2018-2019

Con el fin de mejorar sus productos, Ecopostural se reserva el derecho a modificar cualquier característica técnica y añadir o suprimir productos que aparezcan en este catálogo. Asimismo, declina toda responsabilidad que pueda derivarse de los errores de imprenta, reservándose el derecho a corregirlos. La reproducción fotográfica puede no ser totalmente exacta a la tonalidad de los colores naturales. Este catálogo es propiedad de Ecopostural. No está permitido usar las imágenes contenidas para incluirlas en publicaciones, catálogos u otros usos similares, salvo con el consentimiento expreso de la empresa. Ecopostural, S.L. no se responsabiliza de las acciones que pudieran derivarse del uso indebido del contenido de este catálogo.

Afin d'améliorer ses produits, Ecopostural se réserve le droit de modifier toute caractéristique technique ainsi que de créer ou supprimer des produits inclus dans ce catalogue. En outre, Ecopostural décline toute responsabilité dérivée des erreurs d'imprimerie, tout en maintenant le droit de les corriger. La reproduction photographique des couleurs peut ne pas être exacte à la couleur réelle des produits. Ce catalogue est propriété d'Ecopostural. Il est interdit donc d'utiliser les images contenues pour les mettre dans des publications, catalogues ou bien pour leur donner d'autres usages semblables, sauf autorisation expresse de notre société. Ecopostural, S.L. ne répond pas des actions dérivées du mauvais usage du contenu de ce catalogue.

With the purpose of improving our products, Ecopostural reserves the right to modify any technical data as well as to create or cancel any of the products featured in this catalogue. Furthermore, Ecopostural cannot be held responsible for the printing errors but is entitled to correct them at anytime. The photographic featuring of colours may not be totally accurate. This catalogue is under the ownership of Ecopostural. Any of the images hereinafter contained will not be used for publishing purposes in any catalogue, press article or similar publications unless duly authorised by our company. Ecopostural S.L. will not be held responsible for any action arisen by the misuse of the content of this catalogue.

Um seine Produkte zu verbessern, behält sich Ecopostural das Recht vor, technische Merkmale zu ändern und Produkte, die im Katalog erscheinen, hinzuzufügen oder zu löschen. Ebenso, wird jegliche Verantwortung abgelehnt, die von Druckfehlern abgeleitet werden, und behält sich das Recht vor, sie zu korrigieren. Die fotografische Abbildung, kann möglicherweise, nicht vollständig genau auf den Farbton der natürlichen Farben abstimmen. Dieser Katalog ist Eigentum von Ecopostural. Es ist nicht gestattet, die enthaltenen Bilder zu verwenden, um sie in Publikationen, Kataloge oder andere ähnliche Anwendungen zu integrieren, außer mit ausdrücklicher Zustimmung der Firma. Ecopostural ist nicht verantwortlich für die Handlungen, die durch unsachgemäße Verwendung der Inhalte dieses Katalogs entstehen können.

SOMOS FABRICANTES



ecopostural
mobiliario para la salud.

SOMOS FABRICANTES

La empresa fue fundada en el año 1996 por Santiago Martínez, buen conocedor del sector de la salud natural y de las técnicas de fabricación de mobiliario.

Desde entonces Ecopostural no ha dejado nunca de innovar y lanzar al mercado nuevos productos, resultado de la experiencia acumulada. Además, asistimos a las principales ferias del sector, tanto nacionales como internacionales.

Por otra parte, nuestros diseños son testados y analizados por organismos independientes para garantizar que cumplen con la normativa europea. Asimismo, controlamos todo el proceso de fabricación para que el resultado final sea un artículo de alta calidad y durabilidad lo que nos permite ofrecer una garantía de 3 años.

Estamos seguros de que encontrará el producto más adecuado entre nuestra extensa gama y que quedará satisfecho con nuestro servicio inmediato gracias al amplio stock de materiales.

NOUS SOMMES FABRICANT

L'entreprise a commencé son activité en 1996, fruit des idées et de l'enthousiasme de son fondateur, Santiago Martínez, un expert des techniques de fabrication de mobilier ainsi que du domaine de la santé naturelle.

Depuis, notre entreprise n'a cessé d'innover et de lancer de nouveaux produits sur le marché, résultat de notre expérience accumulée. Nous participons également aux principaux salons du secteur aussi bien au niveau national qu'international.

Tous nos produits sont testés et analysés par des organismes indépendants afin de garantir que ceux-ci sont conformes à la norme européenne. Nous contrôlons toutes les étapes du processus de fabrication pour que le résultat final soit un article durable et de grande qualité, avec une garantie de 3 ans.

Nous sommes sûrs que vous trouverez votre équipement dans notre large gamme de produits et, que vous serez satisfait du service rapide que nous offrons grâce à notre stock permanent de matériaux.

WE ARE MANUFACTURERS

Our company was set up in 1996 by Santiago Martínez, a connoisseur of the natural health domain and the furniture hand making. Since then Ecopostural has been constantly innovating and marketing lots of new products resulting from the vast experience gained through the years. Moreover, we are present at the main exhibitions in our field of national and international scope.

Besides all our products are tested by independent organisms to guarantee they meet with the European regulations. Furthermore, we care the entire manufacturing process to achieve a high quality and high durability product backed by a 3 year guarantee.

We are sure you will find the most adequate product among our vast range and hope you will be satisfied with our short lead times thanks to our large stock of raw materials.

WIR SIND HERSTELLER

Ecopostural ist ein Hersteller von Therapieliegen. Das Unternehmen begann seine Tätigkeit im Jahr 1996, dank der Ideen und der Illusion seines Gründers, Santiago Martínez, ein guter Kenner des Naturheilwesens und der Techniken der Therapieliegen.

Aufgrund der gesammelten Erfahrungen, hat unsere Firma nie aufgehört zu innovieren und neue Produkte auf den Markt zu bringen. Darüber hinaus besuchen wir die wichtigsten Messen der Branche, national wie auch international.

Auf der anderen Seite werden unsere Designs von unabhängigen Stellen getestet und analysiert, um sicherzustellen, dass sie den europäischen Vorschriften entsprechen. Außerdem kontrollieren wir den gesamten Herstellungsprozess, so dass das Endergebnis ein hochwertiges und langlebiges Produkt ist, wessen uns ermöglicht, eine 3-jährige Garantie anzubieten.

Wir sind sicher, dass Sie in unserem umfangreichen Sortiment das passende Produkt finden und dass Sie mit unserem sofortigen Service dank des großen Materialvorrats zufrieden sein werden.



cuida
asociación para
el cuidado de la
calidad de vida



INSTITUTO DE
BIOMECAÍNICA
DE VALENCIA

ENTIDAD ASOCIADA

www.ecopostural.com



ecopostural

www.ecopostural.com



ecopostural
mobiliario para la salud.

Ecopostural, calidad e imagen de siempre pero con un aire renovado: nuevas ideas, nuevos colores y novedosos acabados en nuestros productos. Seguimos trabajando con la misma ilusión y dedicación desde hace más de 20 años para que la rapidez en el servicio y la calidad de nuestros productos sean nuestra mejor garantía. Le invitamos a visitar nuestra web donde podrá conocernos mejor y seguir nuestros movimientos de cerca.

Ecopostural, notre qualité et design avec une touche de renouveau: nouvelles idées, nouvelles couleurs et nouvelles finitions sur nos produits.

Nous continuons à travailler avec le même enthousiasme et engagement depuis plus de 20 ans afin de garantir un service rapide et des produits de qualité.

Nous vous invitons à consulter notre site internet pour mieux connaître notre entreprise et suivre notre actualité.

Ecopostural, the same quality and service as usually but showing a refreshed image: new ideas, new colours and new finishing on our products.

We keep working with the same eagerness and devotion since our very beginning more than 20 years ago with the aim of offering the best service possible, short leading times and an excellent quality.

For further details about our company and our latest news please enter our website.

Ecopostural, Qualität und Image von immer, aber mit einer erneuerten Brise: neue Ideen, neue Farben und neue Ausführungen an unseren Produkten.

Wir arbeiten seit mehr als 20 Jahren mit derselben Begeisterung und Hingabe, so dass die Schnelle des Services und die Qualität unserer Produkte unsere beste Garantie sind.

Wir laden Sie ein, unsere Website zu besuchen, wo Sie uns besser kennenlernen und unsere Bewegungen genau verfolgen können.

www.ecopostural.com



FABRICACIÓN ESMERADA

FABRICATION SOIGNÉE
DETAILED MANUFACTURING
SORGFÄLTIGE PRODUKTION



CALIDAD EN ACABADOS

FINITIONS DE QUALITÉ
HIGH QUALITY FINISH
HOCHWERTIGE VERARBEITUNG



CONTROL

CONTRÔLE
CONTROL
KONTROLLE



I + D + i INNOVACIÓN

INNOVATION
INNOVATION
INNOVATION



STOCK PERMANENTE

STOCK PERMANENT
PERMANENT STOCK
PERMANENTER LAGERBESTAND



SERVICIO INMEDIATO

SERVICE IMMÉDIAT
ACCURATE SERVICE
SCHNELLER LIEFERSERVICE



PRESENCIA INTERNACIONAL

PRÉSENCE INTERNATIONALE
WORLD WIDE PRESENCE
INTERNATIONALE PRÄSENZ



AMPLIA GARANTÍA

GARANTIE FIABLE
WIDE GUARANTEE
3 JAHRES GARANTIE

CALIDAD Y GARANTIA ECOPOSTURAL

Al adquirir cualquier modelo de nuestra extensa gama obtiene un producto que responde a los más altos niveles de calidad: fabricado en España aplicando la normativa europea CE, testado por el IBV (Instituto de Biomecánica de Valencia), creado teniendo presente nuestro respeto por el medio ambiente durante todo el proceso de fabricación, de gran durabilidad y con una garantía de 3 años.

En achetant un produit de la gamme Ecopostural, vous avez en main un produit qui répond à des critères de très grande qualité: fabriqué en Espagne, conforme à la norme européenne CE, testé par l'IBV (Institut de Biomécanique de Valencia), élaboré dans le respect de l'environnement, durable et avec une garantie 3 ans.

When buying any of our products you can be sure it will meet the highest quality standards: manufactured in Spain observing the specific European regulations, tested by the IBV (Valencian Biomechanics Institute), fully respectful with the environment during the whole manufacturing process, highly durable and covered by a 3 year guarantee.

Wenn Sie ein Modell unseres umfangreichen Sortiments erwerben, erhalten Sie ein Produkt, das den höchsten Qualitätsansprüchen gerecht wird: Hergestellt in Spanien unter Anwendung der europäischen CE-Vorschriften, getestet von IBV (Institut für Biomechanik in Valencia), erstellt mit Respekt für die Umwelt während des Herstellungsprozesses, von großer Haltbarkeit und mit einer 3-Jahres-Garantie.



8-13 / **INFORMACIÓN TÉCNICA**
Information Technique · Technical Information · Technische Information

14-25 / **CAMILLAS MULTIFUNCIONALES**
Tables Multi-fonction · Multi-function Tables · Multifunktionelle Therapieliegen

26-51 / **CAMILLAS TÉCNICAS**
Tables Techniques · Technical Tables · Technische Therapieliegen

52-67 / **CAMILLAS Y SILLONES DE ESPECIALIDAD**
Tables et Fauteuils pour les Spécialités · Speciality Tables and Chairs · Spezialliegen / Stühle

54 · 60
61 · 67 / **CAMILLAS DE ESPECIALIDAD · SILLONES DE ESPECIALIDAD**
Tables pour les spécialités · Speciality tables · Spezialliegen/Stuhl · Fauteuils pour les spécialités · Speciality chairs · Untersuchungsstühle für Spezialität

68-77 / **CAMILLAS DE 3 CUERPOS**
Tables 3 plans · 3 section tables · Therapieliegen mit 3 Segmente

78-93 / **CAMILLAS DE 2 CUERPOS**
Tables 2 plans · 2 section tables · Therapieliegen mit 2 Segmente

94-105 / **CAMILLAS FIJAS**
Tables Fixes · Stationary Tables · Stationäre Therapieliegen
96 · 99
100 · 103
104-105 / **CAMILLAS FIJAS DE 3 CUERPOS · CAMILLAS FIJAS DE 2 CUERPOS · PACK EQUIPAMIENTO**
Tables fixes 3 plans · 3 section stationary tables · Stationäre Liegen mit 3 Segmente · Tables fixes 2 plans · 2 section stationary tables · Stationäre Liegen mit 2 Segmente · Pack mobilier · Furniture set · Einrichtungs – Pack

106-115 / **CAMILLAS PLEGABLES**
Tables Pliantes · Portable Tables · Koffermassagebank
108 · 114
114
115 / **CAMILLAS PLEGABLES ALTURA REGULABLE · CAMILLAS PLEGABLES TÉCNICAS · CAMILLAS PLEGABLES ALTURA FIJA**
Tables pliantes hauteur réglable · Portable tables adjustable height · Klappbare Liegen mit Höhenverstellung · Tables pliantes techniques · Technical portable tables · Klappbare Liegen für spez. Techniken · Tables pliantes hauteur fixe · Portable tables non-adjustable height · Klappbare Liegen mit fester Höhe

116-119 / **TABLA DE INVERSIÓN / SILLA MULTIFUNCIONAL PARA TERAPIAS**
Table d'inversion / Chaise multi-fonction pour thérapies · Inversion table / Multi-function therapy chair · Inversions- Liege / Therapiestuhl

118
119
119 / **TABLA DE INVERSIÓN · SILLA MULTIFUNCIONAL PARA TERAPIAS · SOPORTE PARA MASAJE**
Table d'inversion · Inversion table · Inversions- Liege · Chaise multi-fonction pour thérapies · Multi-function therapy chair · Therapiestuhl · Modèle pliant pour massage · Foldable model for massage · Tischaufsatz

120-127 / **TABURETES Y SILLAS**
Tabourets et Chaises · Stools and Chairs · Hocker und Stühle
122 · 125
126 · 127 / **TABURETES · SILLAS ERGONÓMICAS**
Tabourets · Stools · Hocker · Chaises ergonomiques · Ergonomic chairs · Ergonomische Stühle

128-133 / **ACCESORIOS Y COJINES**
Accessoires et Coussins · Accessories and Bolsters · Zubehör und Lagerungsmaterial
130 · 131
132 · 133 / **ACCESORIOS · COJINES**
Accessoires · Accessories · Zubehör · Coussins · Bolsters · Lagerungskissen

134-141 / **RESUMEN**
Résumé · Summary · Überblick

SISTEMA DE ELEVACIÓN

Mécanismes pour le réglage de la hauteur
Height adjustment mechanisms
Hebesystem

MOTOR ELÉCTRICO
Moteur électrique
Electric system
Elektrischer Motor

MOTOR RÁPIDO
Moteur rapide
High-speed motor
Schneller Motor

ELEVADOR HIDRÁULICO
Pompe hydraulique
Hydraulic system
Hydraulische Höhenverstellung

ACCIONAMIENTO PERIFÉRICO
Cadre périphérique
Side rails system
Rundumschaltung

TIPOS DE ELEVACIÓN

Élévation
Elevation
Höhenverstellung

CON DESPLAZAMIENTO LATERAL
Déport latéral
Side misalignment
Mit seitlicher Verschiebung

SIN DESPLAZAMIENTO LATERAL
Sans déport
Vertical alignment
Ohne seitliche Verschiebung

PESO MÁXIMO RECOMENDADO

Charge maximale recommandée
Recommended maximum weight
Maximalgewicht empfohlen

GROSOR DE LA ESPUMA

Épaisseur de mousse
Foam thickness
Dicke des Schaumstoffes

GRADO DE FIRMEZA DE LA ESPUMA

Soutien de mousse
Foam firmness
Härtegrad des Schaumstoffes

135 Kg

150 Kg

175 Kg

200 Kg

250 Kg

2cm

3cm

4cm

5cm

6cm

7cm

I - Blando
I - Souple
I - Extra soft
I - Weich

II - Medio
II - Équilibré
II - Soft
II - Ausgeglichen

III - Semiduro
III - Ferme
III - Medium firm
III - Halbhart

IV - Duro
IV - Très ferme
IV - Firm
IV - Hart

V - Extraduro
V - Dur
V - Extra firm
V - Extrem Hart

SISTEMA DE REGULACIÓN DE LOS MÓDULOS

Réglage des plateaux
Sections adjustment
Regulierungssystem

SIMBOLOGÍA TABURETES

Symboles tabouret
Stool symbols
Zeichenerklärung Hocker

Cabezal / Respaldo
Tête / Dossier
Head- / Backrest
Kopfteil / Rückenlehne

Central
Partie centrale
Central section
Mittelteil

Cabezal / Respaldo
Tête / Dossier
Head- / Backrest
Kopfteil / Rückenlehne

Central
Partie centrale
Central section
Mittelteil

Pies
Jambes
Feet section
Beinteil

Brazo lateral
Panneaux latéraux
Side support
Seitliche Armstützen

Cabezal / Respaldo
Tête / Dossier
Head- / Backrest
Kopfteil / Rückenlehne

Central
Partie centrale
Central section
Mittelteil

Pies
Jambes
Feet section
Beinteil

ELÉCTRICO
Électrique
Electric motor
Elektrisch

HIDRÁULICO
Hydraulique
Hydraulic pump
Hydraulisch

MANUAL
Manuel
Manually
Manuel

ASIENTO BASCULANTE
Siège inclinable
Seat tilt
Sitzfläche schwenkbar

ACCIONAMIENTO DE PIE
Déclenchement au pied
Foot-operated
Fussantrieb

MOVIMIENTOS
Mouvements
Movements
Bewegungen

ALTURA REGULABLE
Hauteur réglable
Adjustable height
Höhe verstellbar

ALTURA FIJA
Hauteur fixe
Non-adjustable height
Feste Höhe

PATAS DESMONTABLES
Pieds démontables
Collapsible legs
Abnehmbare Beine

PESO DEL ARTÍCULO
Poids
Weight
Produktgewicht

17 Kg

CAMILLA DE MADERA
Table en bois
Wooden table
Holzliege

CAMILLA MIXTA
Table mixte
Mixed table
Therapieliege Mix

CAMILLA DE ALUMINIO
Table en aluminium
Aluminium table
Therapieliege aus Aluminium

CAMILLA DE ACERO
Table en acier
Steel table
Therapieliege aus Stahl

SIMBOLOGÍA CAMILLAS FIJAS Y PLEGABLES

Symboles tables fixes & pliantes
Symbols used for stationary & portable tables
Zeichenerklärung von stationären und klappbaren Therapieliegen

CAMILLA CON RODAMIENTO
Chassis avec roulements
With bearings
Therapieliegen mit Kugellager

CAMILLA CON RODAMIENTO
Chassis avec roulements
With bearings
Therapieliegen mit Kugellager

Ecopostural se reserva el derecho a modificar sus productos y características técnicas. Las medidas y pesos finales de los productos pueden variar respecto de los aquí indicados: medidas ± 5cm / pesos ± 2kg / movimientos ± 10°

Ecopostural se réserve le droit de modifier ses produits et caractéristiques techniques. Les dimensions et poids indiqués dans ce catalogue sont donnés à titre indicatif et peuvent varier: dimensions ± 5cm / poids ± 2kg / mouvements ± 10°

Ecopostural reserves the right to modify its products and make changes in technical data. Actual dimensions and weights may vary from the values indicated in this catalogue: dimensions ± 5cm / weight ± 2kg / movements ± 10°

Ecopostural behält sich das Recht vor, seine Produkte und technischen Eigenschaften zu ändern. Die Maße und Endgewichte der Produkte können von den hier angegebenen abweichen: Maße + - 5cm / Gewicht + - 2 kg / Bewegungen 10°

AMPLIAMOS INFORMACIÓN E IDIOMA

En la edición anterior les presentamos un nuevo concepto de catálogo. Tras la buena acogida obtenida, hemos continuado trabajando para mejorar, si cabe, este tipo de formato. En esta edición ampliamos la información de los movimientos de las camillas con nuevos esquemas que muestran la versatilidad en cuanto a las diferentes posiciones del paciente. Y, por último, les presentamos la **nueva generación de rodamientos** en las series **5500 / 5700** cuyo resultado es un diseño silencioso, con movimientos más constantes y sutiles y un mínimo mantenimiento. Además, incorporamos 3 nuevos colores a nuestra gama de tapizado con el fin de satisfacer la demanda de nuestros clientes.

TOUJOURS PLUS D'INFORMATION
Dans l'édition précédente, nous vous avons présenté un nouveau concept de catalogue. Comme la formule a été très bien accueillie, nous avons continué sur cette ligne en améliorant encore ce format. Dans cette édition 2018-2019, nous avons élargi l'information concernant les mouvements des tables avec de nouveaux schémas qui montrent le positionnement du patient sur les sections. Dernier point important, nous vous présentons la **nouvelle génération de châssis avec roulements** pour les séries **5500 / 5700** qui se caractérise par des mouvements fluides et souples, silencieux et, par un entretien minimum. Également, nous avons incorporé 3 nouveaux coloris à notre gamme de similicuir afin de répondre à la demande de nos clients.

A NEW SCOPE OF INFORMATION
Our 2015 catalogue meant a new concept of catalogue. After the warm welcome we have worked in the same line to enhance this type of format. In this edition we include a graphic support of the different positions of the table sections with the aim of showing the large possibilities of our products. Last but not least, we also show our **new generation of bearings** in ranges **5500 / 5700** resulting in a silent design, with smooth and steady movements and a minimum maintenance. Furthermore, 3 new colours have been added to our upholstery range thus satisfying the demands of our customers.

WIR ERWEITERN DIE INFORMATION
In der vorherigen Ausgabe haben wir ein neues Katalogkonzept vorgestellt. Nach dem guten Empfang haben wir weiter daran gearbeitet, wenn möglich, um diese Art von Format zu verbessern. In dieser Ausgabe erweitern wir die Informationen über die Bewegungen der Therapieliegen mit neuen Schemata und zeigen die Vielseitigkeit in Bezug auf die verschiedenen Positionen des Patienten zeigen. Und schließlich präsentieren wir die **neue Generation von Kugellagern** bei der Serie **5500 / 5700**, die zu einem geräuscharmen Design mit konstanteren und subtileren Bewegungen und minimaler Wartung führt. Darüber hinaus integrieren wir 3 neue Farben in unsere Polsterkollektion, um den Anforderungen unserer Kunden gerecht zu werden.

CLASIFICACIÓN DEL PRODUCTO
CATÉGORIE PRODUIT
PRODUCT CLASS
PRODUKTEKATEGORIE

CAMILLAS MULTIFUNCIONALES
TABLES MULTI-FONCTION · MULTI-FUNCTION TABLES
MULTIFUNKTIONELLE THERAPIELIEGEN

VERSATILIDAD DE POSICIONES
POSITIONNEMENT DU PATIENT
PATIENT POSITIONING
MÖGLICHKEIT AN STELLUNGEN

TIPOS DE CABEZAL / RESPALDO
TYPES DE TÊTIÈRE/DOSSIER
TYPES OF HEAD-/BACKREST
KOPFTEILE/RÜCKENTEILE

TIPOS DE CABEZAL
TYPES DE TÊTIÈRE
TYPES OF HEADREST
KOPFTEILE

TIPOS DE CABEZAL / RESPALDO
TYPES DE TÊTIÈRE/DOSSIER
TYPES OF HEAD-/BACKREST
KOPFTEILE/RÜCKENTEILE

www.ecopostural.com

STANDARD BAJO PEDIDO / SUR DEMANDE / ON ORDER / AUF ANFRAGE

45 55 95 62

Standard: 62 x 200 cm. (M47)

C5931 **C7931**

C5531 **C7531**

C5731 **C7731**

C5931 **C7931** **C5531 / C5731** **C7531 / C7731**

MEDIDAS STANDARD DE LAS SECCIONES
DIMENSIONS STANDARD DES SECTIONS
TABLE SECTION STANDARD SIZES
STANDARDMASSE DER SEGMENTE

GROSOR DE LA ESPUMA
ÉPAISSEUR DE MOUSSE
FOAM THICKNESS
DICKE DES SCHAUMSTOFFES

GRADO DE FIRMEZA DE LA ESPUMA
SOUTIEN DE MOUSSE
FOAM FIRMNESS
HÄRTEGRAD DES SCHAUMSTOFFES

MEDIDAS DE LECHO DISPONIBLE
DIMENSIONS DISPONIBLES
AVAILABLE DIMENSIONS
VERFÜGBARE SEGMENTMASSE

CÓDIGO DEL PRODUCTO
CODE PRODUIT
PRODUCT CODE
PRODUKTECODE

CARACTERÍSTICAS DEL PRODUCTO
CARACTÉRISTIQUES PRODUIT
PRODUCT FEATURES
PRODUKTEIGENSCHAFT

COLORES DISPONIBLES
COULEURS DISPONIBLES
AVAILABLE COLOURS
FARBENAUSWAHL

COLOR DE LAS IMÁGENES
COULEUR DE LA PHOTO
FEATURED PRODUCT COLOUR
FARBE DER ANZEIGE

MOVIMIENTOS SEGÚN MODELO
ARTICULATIONS & MOUVEMENTS
TILTS & MOVEMENTS
BEWEGUNGEN GEMÄSS THERAPIELIEGE

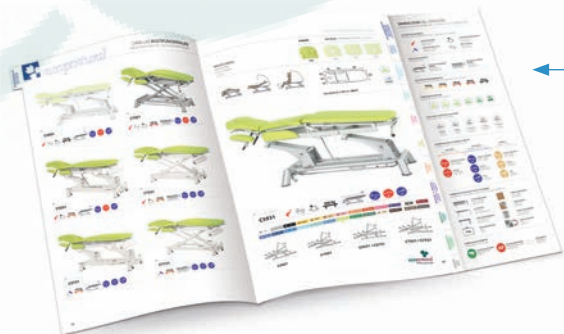

CATÁLOGO ABIERTO CON SOLAPA DESPLEGADA
CATALOGUE OUVERT AVEC RABAT DÉPLIÉ
FULLY OPEN CATALOGUE WITH UNFOLD FLAP
KATALOG MIT GEÖFFNETER KLAPPE



Ecopostural se reserva el derecho a modificar sus productos y características técnicas. Las medidas y pesos finales de los productos pueden variar respecto de los aquí indicados: medidas ± 5cm / pesos ± 2kg / movimientos ± 10°

Ecopostural se réserve le droit de modifier ses produits et caractéristiques techniques. Les dimensions et poids indiqués dans ce catalogue sont donnés à titre indicatif et peuvent varier: dimensions ± 5cm / poids ± 2kg / mouvements ± 10°

Ecopostural reserves the right to modify its products and make changes in technical data. Actual dimensions and weights may vary from the values indicated in this catalogue: dimensions ± 5cm / weight ± 2kg / movements ± 10°

Ecopostural behält sich das Recht vor, seine Produkte und technischen Eigenschaften zu ändern. Die Maße und Endgewichte der Produkte können von den hier angegebenen abweichen: Maße + - 5cm / Gewicht + - 2kg / Bewegungen 10°



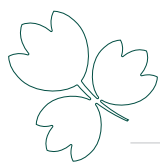

TIPOS DE ACCIONAMIENTO DEL SISTEMA DE ELEVACIÓN

MÉCANISMES POUR LE RÉGLAGE DE LA HAUTEUR · HEIGHT ADJUSTMENT MECHANISMS · HÖHENEINSTELLUNGEN

TIPOS DE REGULACIÓN DE LOS MÓDULOS

RÉGLAGE DES PLATEAUX · SECTIONS ADJUSTMENT · SYSTEM-EINSTELLUNG DER SEGMENTE

CON PERIFÉRICO SYSTÈME PÉRIPHÉRIQUE ELECTRIC SIDE RAILS RUNDUMSCHALTUNG

El accionamiento periférico es una barra situada alrededor de la base de la camilla. Para activarlo empújela suavemente con el pie hacia arriba a la derecha o a la izquierda.

¡NO PISAR!

Le système périphérique est une barre située autour de la base de la table. Pour changer la hauteur, déplacer la barre légèrement à droite ou à gauche avec le pied.

NE JAMAIS appuyer sur la barre!

The side rails is a rail located around the base of the table. The height is adjusted by smoothly pushing the foot rail sideways (right/left).

DO NOT press down!

Bietet eine bequeme Ansteuerung per Fuß von allen Seiten der Behandlungsfläche.

Der Rundumschalter wird über ein Metallgestänge, oder an der Kopf- oder Fußseite per Gummipedale bedient. Um es zu aktivieren, heben Sie es sanft mit dem Fuß nach oben und danach rechts oder links. Am Kopfteil / Beinteil nach vorne oder hinten.

ACHTUNG nicht nach unten drücken



SERIE 5900



SERIE 7900



SERIE 5500



SERIE 7500

CON MANDO DE PIE PÉDALE · FOOT PEDAL FUßSTEUERUNG

Presione el interruptor con el pie hasta conseguir la altura deseada, izquierda ↓ para bajar / derecha ↑ para subir.

Appuyer sur l'interrupteur à pied jusqu'à la hauteur souhaitée, gauche ↓ pour descendre / droite ↑ pour monter.

Press the foot control switch pedal to adjust the height, left ↓ downwards / right ↑ upwards.

Fußschalter auf den Boden legen. Diese sind mit einem Kabel an den Motor angeschlossen.

Drücken Sie den Schalter mit Ihrem Fuß, bis Sie die gewünschte Höhe erreicht haben, links ↓, nach unten / rechts ↑ nach oben.



SERIE 3500



SERIE 3500

CON PEDAL HIDRÁULICO PÉDALE HYDRAULIQUE HYDRAULIC FOOT PUMP HYDRAULIK MIT FUßHEBEL

Empuje el pedal hasta abajo, con cada presión la camilla subirá unos centímetros. Para bajar, eleve el pedal con el pie y la camilla descenderá suavemente.

Appuyer plusieurs fois avec le pied sur la pédale pour faire monter la table; la table montera de quelques centimètres à chaque fois. Pour baisser, soulever la pédale avec le pied et la table descendra doucement.

Press the lever with the foot in order to lift the table. With every stroke the table will go up a few centimeters. Raise the lever with the foot and the table will get down gently.

Drücken Sie den Hebel nach unten. Mit jedem Druck, bewegt sich die Liege nach oben. Um die Liege zu senken, den Fußhebel nach oben ziehen und die Liege wird leicht herunterfahren.



SERIE 5700



SERIE 7700



MANUAL MANUEL · MANUALLY · MANUEL

Con una mano gire el pomo o levante la palanca para liberar la barra y con la otra sitúe el módulo a la inclinación deseada, quedando fijo al soltar el pomo o palanca.

Avec une main, tourner le pommeau ou la manette pour libérer la barre et avec l'autre main, placer le plateau à la position souhaitée. Pour fixer la position, relâcher le pommeau ou la manette.

With one hand, loosen the knob or lever to release the bar. With the other hand, position the section at the required tilting. Release the knob or lever and the section will lock itself.

Stangenmechanismus mit Bremse. Mit einer Hand den Knopf drehen und den Hebel anheben, um die Stange zu lösen und das Modul in die gewünschte Neigung setzen, beim loslassen des Knopfes wird der Hebel fixiert.

CON POMO / PALANCA POMMEAU / MANETTE · KNOB / LEVER MIT KNOPF / HEBEL



Eleve el módulo a la altura precisada y la cremallera se posicionará sola. Para bajarlo, primero deberá elevarlo al máximo para desbloquear el mecanismo.

Asegúrese que ambos lados queden bien fijados y a la misma altura.

Lever le plateau jusqu'à la hauteur souhaitée et la crémaillère se positionnera seule. Pour le baisser, lever le plateau (dans certains cas au maximum) pour débloquer la crémaillère, puis baisser le plateau.

Les crémaillères doivent être bien enclenchées au même niveau de chaque côté.

Lift the section up to the required position and the rack will position itself automatically. To lower the section, first raise it up to a certain extent or completely (as appropriate) in order to release the rack.

The hinges on both sides must be properly fixed and positioned at the same height.

Mehrfachpositions-Rack-Scharniermechanismus. Heben sie das Modul auf die gewünschte Höhe und das Rack positioniert sich. Um es zu senken, müssen Sie es zuerst bis zum Maximum anheben, um den Mechanismus zu entsperren.

Stellen sie sicher, dass beide seiten auf gleicher höhe sind.

CON CREMALLERA CRÉMAILLÈRE · RACK MIT KLEMMSYSTEM

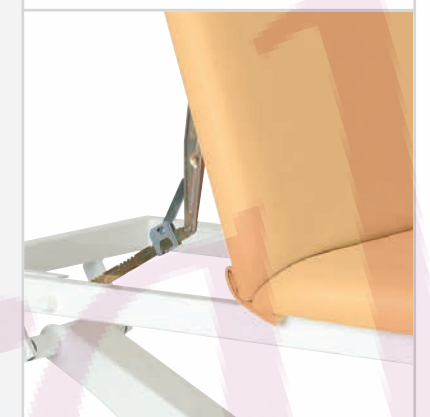

HIDRÁULICO HYDRAULIQUE · HYDRAULIC PUMP · HYDRAULISCH

Presione la palanca situada debajo del tapizado para activar el hidráulico y el módulo irá subiendo. Al soltarla se quedará fijo. Para bajarlo mantenga presionada la palanca con una mano y con la otra empuje el módulo hasta la posición deseada.

Appuyer sur le mécanisme situé derrière le plateau en direction du ski. Le plateau montera peu à peu. Pour fixer la position, relâcher le mécanisme. Pour baisser le plateau, appuyer sur le mécanisme avec une main et avec l'autre main, baisser le plateau jusqu'à la position souhaitée.

Press the mechanism situated at the very edge of the section towards the upholstery and the table section will go up slowly. Release mechanism to lock position. To lower the section, press the mechanism with one hand and with the other hand, push the section downwards to the required position.

Zum Aktivieren drücken Sie den Hebel unter der Polsterung und das Modul fährt hoch. Beim freigeben des Hebels wird die Höhe fixiert. Zum Absenken halten Sie den Hebel mit der Hand und drücken Sie die Rückenlehne mit der anderen in die gewünschte Position.

CON HIDRÁULICO VÉRIN À GAZ · GAS SPRING MIT GASDRUCKFEDER



ELÉCTRICO ÉLECTRIQUE · ELECTRIC MOTOR · ELEKTRISCH

Presione el interruptor de subida o bajada del mando hasta conseguir la inclinación que le interese.

Dispone de dos mandos, uno a cada lateral.

Pour changer l'inclinaison, il faut appuyer sur le bouton presseur de montée ou de descente.

Il y a 1 commande manuelle de chaque côté de la table.

Press the hand control switch to position the section at the required tilting.

There is 1 hand control switch on each side of the table.

Um die Senkung zu erhalten, die Sie interessiert, drücken Sie auf den Schalter, um es zu heben oder zu senken.

Achtung: hat zwei Mechanismen, eines auf jeder Seite.

CON MOTOR VÉRIN ÉLECTRIQUE · ELECTRIC MOTOR MECHANISMUS MIT MOTOR



ecopostural
mobiliario para la salud.

MULTIFUNCIONALES
MULTI-FUNCTION · MULTI-FUNCTION · MULTIFUNKTIONELLE

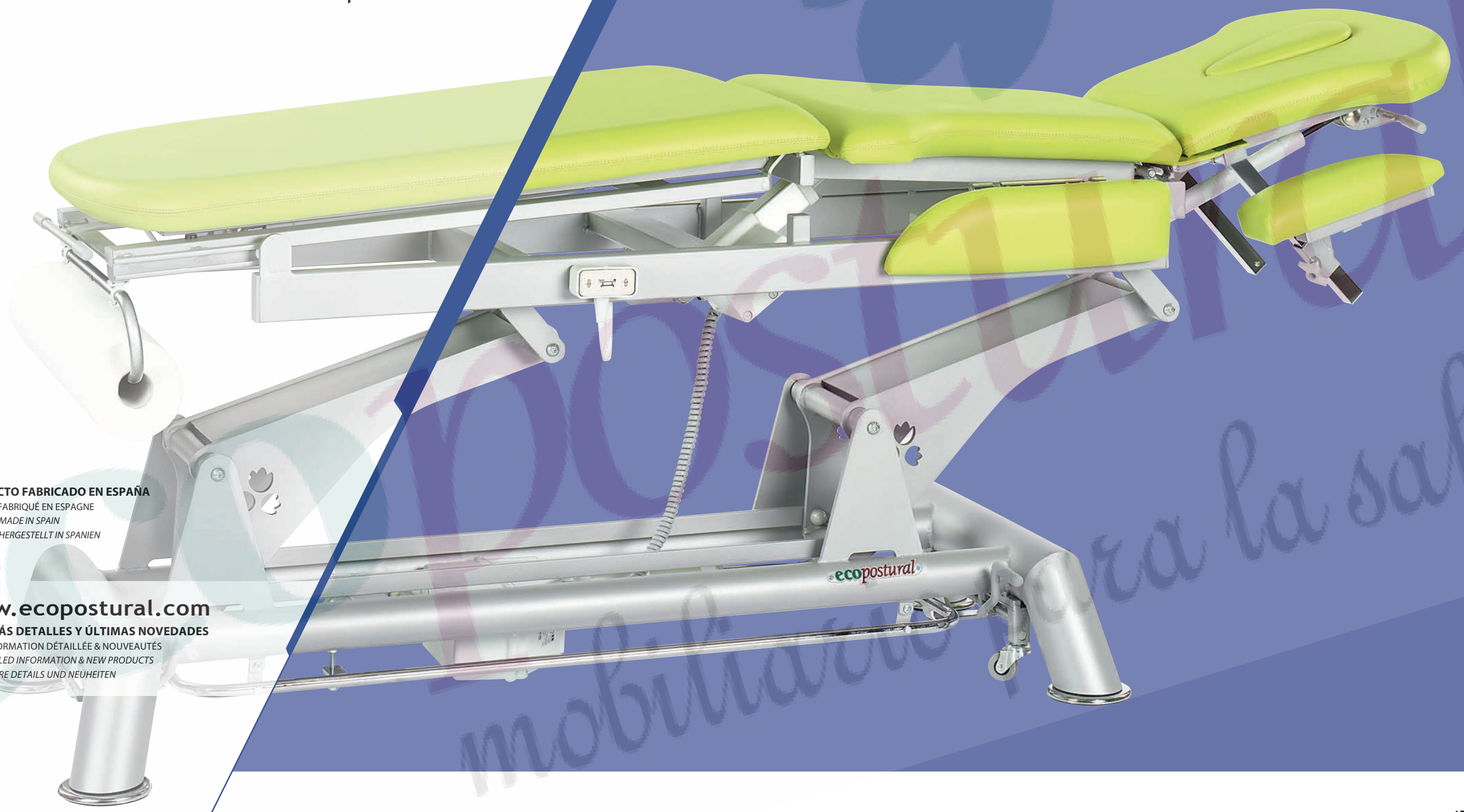

PRODUCTO FABRICADO EN ESPAÑA
PRODUIT FABRIQUÉ EN ESPAGNE
PRODUCT MADE IN SPAIN
PRODUKT HERGESTELLT IN SPANIEN



www.ecopostural.com
PARA MÁS DETALLES Y ÚLTIMAS NOVEDADES
POUR INFORMATION DÉTAILLÉE & NOUVEAUTÉS
FOR DETAILED INFORMATION & NEW PRODUCTS
FÜR WEITERE DETAILS UND NEUHEITEN



C5931

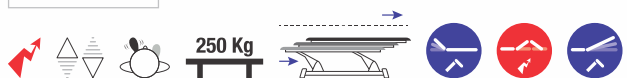

C7931



C5531

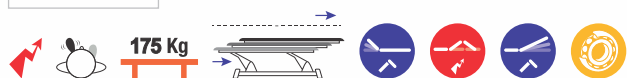

C7531



C5731

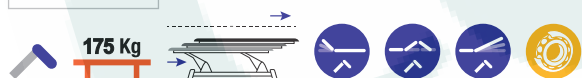

C7731

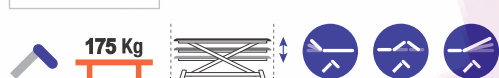

TIPOS DE CABEZAL

TYPES DE TÊTIÈRE
TYPES OF HEADREST
KOPFTEILE

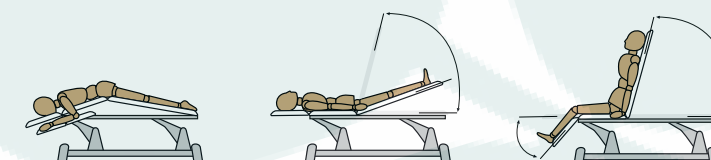

STANDARD



T 01

BAJO PEDIDO / SUR DEMANDE / ON ORDER / AUF ANFRAGE



T 02



T 03



T 04

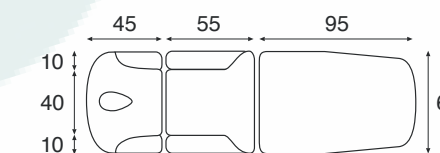

Standard: 62 x 200 cm. (M47)



C5931

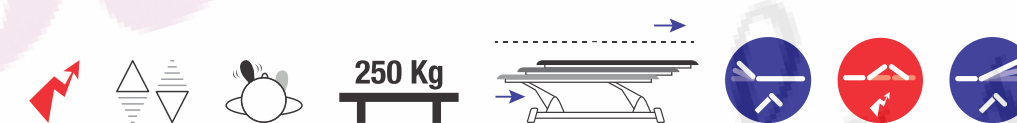

41 Blanc	42 Gris	43 Noir	44 Jonquille	45 Banane	46 Ocre	47 Rose	48 Clémentine	49 Coquelicot	50 Framboise	51 Iris	NEW 30 Cherry	
52 Lilas	53 Roi	54 Bleuets	55 Ciel	56 Sanitaire	57 Java	58 Kiwi	59 Gazon	60 Celadon	61 Crème	62 Marron	31 Smoke	32 Anthracite

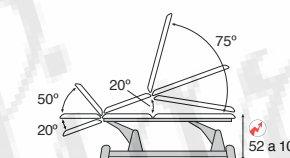

C5931

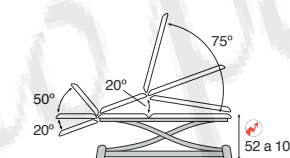

C7931

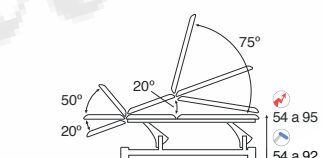

C5531 / C5731

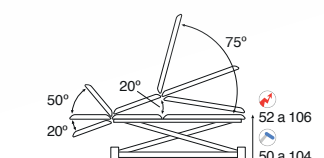

C7531 / C7731



C5930

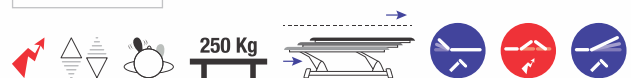

C7930



C5530

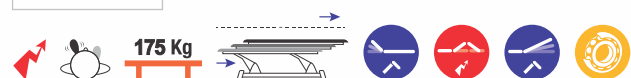

C7530



C5730

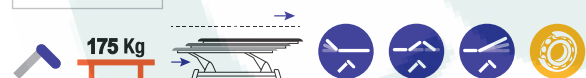

C7730

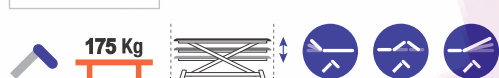

TIPOS DE CABEZAL

TYPES DE TÊTIÈRE
TYPES OF HEADREST
KOPFTEILE

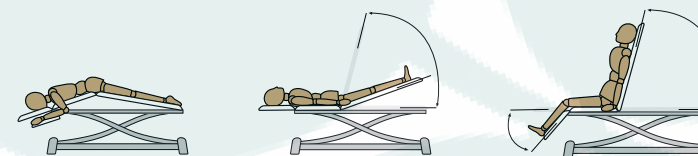

STANDARD



T 01

BAJO PEDIDO / SUR DEMANDE / ON ORDER / AUF ANFRAGE



T 02



T 03



T 04

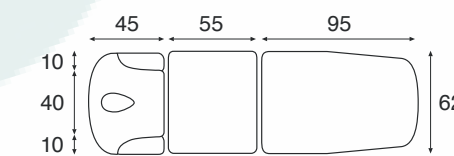

Standard: 62 x 200 cm. (M47)



C7930



41 Blanc	42 Gris	43 Noir	44 Jonquille	45 Banane	46 Ocre	47 Rose	48 Clémentine	49 Coquelicot	50 Framboise	51 Iris	NEW	30 Cherry
52 Lilas	53 Roi	54 Bleuets	55 Ciel	56 Sanitaire	57 Java	58 Kiwi	59 Gazon	60 Celadon	61 Crème	62 Marron	31 Smoke	32 Anthracite

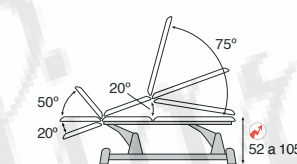

C5930

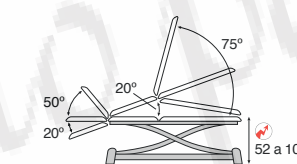

C7930

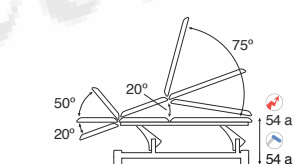

C5530 / C5730

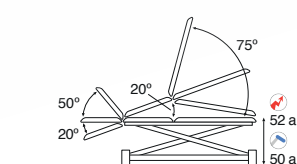

C7530 / C7730



C5921

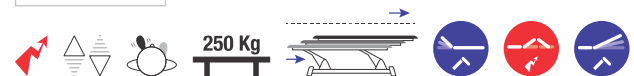

C7921



C5521

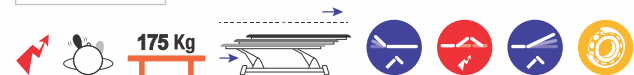

C7521



C5721

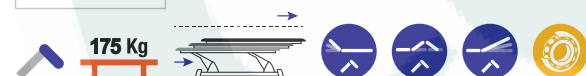

C7721

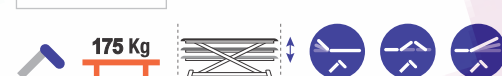

TIPOS DE CABEZAL

TYPES DE TÊTIÈRE
TYPES OF HEADREST
KOPFTEILE

STANDARD

BAJO PEDIDO / SUR DEMANDE / ON ORDER / AUF ANFRAGE



T 10



T 11



T 12



T 07



T 08



T 09

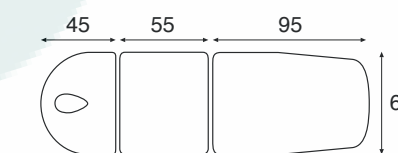
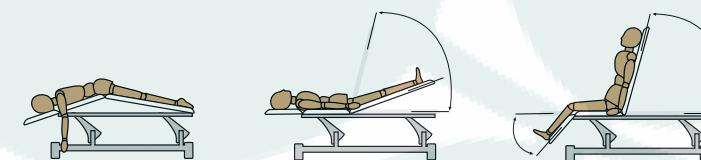

Standard: 62 x 200 cm. (M47)



C5521

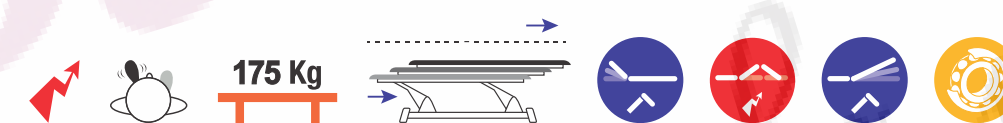

41 Blanc	42 Gris	43 Noir	44 Jonquille	45 Banane	46 Ocre	47 Rose	48 Clémentine	49 Coquelicot	50 Framboise	51 Iris	NEW	30 Cherry
52 Lilas	53 Roi	54 Bleuets	55 Ciel	56 Sanitaire	57 Java	58 Kiwi	59 Gazon	60 Celadon	61 Crème	62 Marron	31 Smoke	32 Anthracite

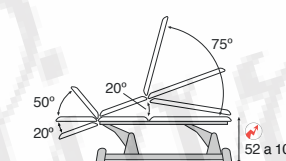

C5921

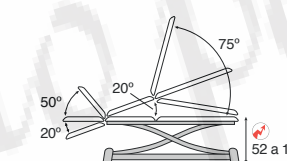

C7921

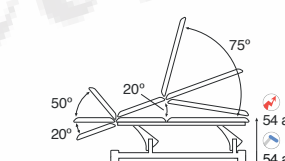

C5521 / C5721

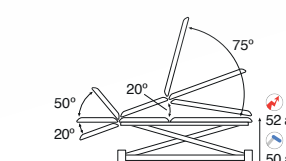

C7521 / C7721



C5990

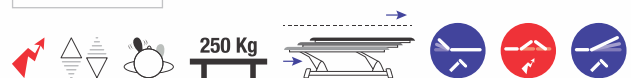

C7990



C5590

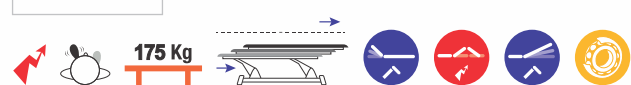

C7590



C5790

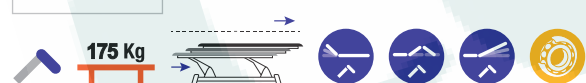

C7790

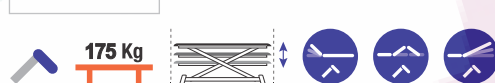

TIPOS DE CABEZAL

TYPES DE TÊTIÈRE
TYPES OF HEADREST
KOPFTEILE

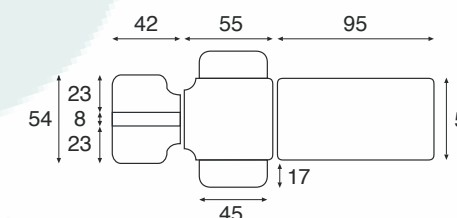
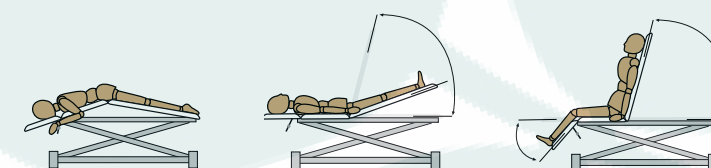

Standard: 50 x 198 cm. (M16)



C7790



41 Blanc	42 Gris	43 Noir	44 Jonquille	45 Banane	46 Ocre	47 Rose	48 Clémentine	49 Coquelicot	50 Framboise	51 Iris	NEW 30 Cherry	
52 Lilas	53 Roi	54 Bleuets	55 Ciel	56 Sanitaire	57 Java	58 Kiwi	59 Gazon	60 Celadon	61 Crème	62 Marron	31 Smoke	32 Anthracite

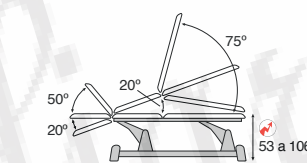

C5990

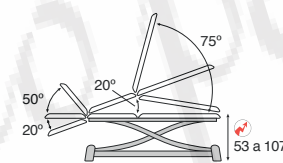

C7990

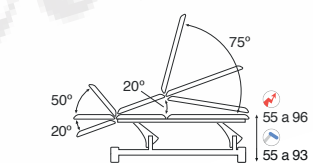

C5590 / C5790

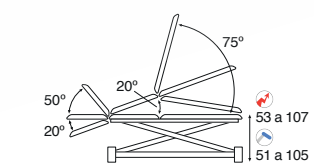

C7590 / C7790

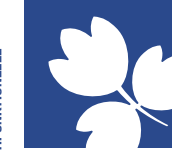

C5991
250 Kg
[Icons: height, weight, wheels, table height, table width, table depth]



C7991
200 Kg
[Icons: height, weight, wheels, table height, table width, table depth]



C5591
175 Kg
[Icons: height, weight, wheels, table height, table width, table depth]



C7591
175 Kg
[Icons: height, weight, wheels, table height, table width, table depth]



C5791
175 Kg
[Icons: height, weight, wheels, table height, table width, table depth]



C7791
175 Kg
[Icons: height, weight, wheels, table height, table width, table depth]

TIPOS DE CABEZAL
TYPES DE TÊTIÈRE
TYPES OF HEADREST
KOPFTEILE

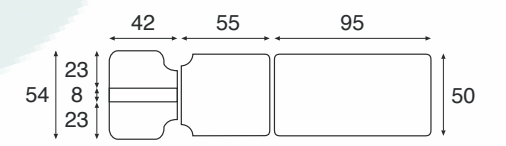
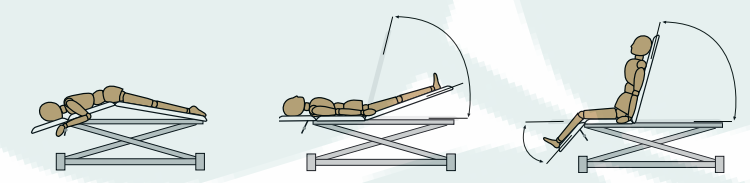

C7591 175 Kg
[Icons: height, weight, wheels, table height, table width, table depth]

41 Blanc	42 Gris	43 Noir	44 Jonquille	45 Banane	46 Ocre	47 Rose	48 Clémentine	49 Coquelicot	50 Framboise	51 Iris	NEW 30 Cherry
52 Lilas	53 Roi	54 Bleuets	55 Ciel	56 Sanitaire	57 Java	58 Kiwi	59 Gazon	60 Celadon	61 Crème	62 Marron	31 Smoke 32 Anthracite

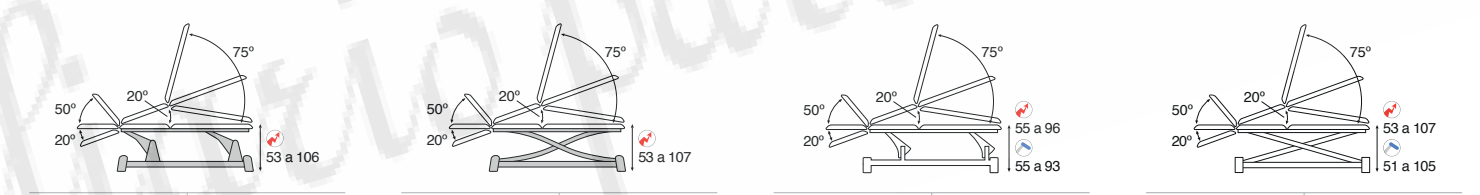

C5991 **C7991** **C5591 / C5791** **C7591 / C7791**



eco postural
mobiliario para la salud.

TÉCNICAS

TECHNIQUES · TECHNICAL · TECHNIKEN



PRODUCTO FABRICADO EN ESPAÑA
PRODUIT FABRIQUÉ EN ESPAGNE
PRODUCT MADE IN SPAIN
PRODUKT HERGESTELLT IN SPANIEN



www.ecopostural.com
PARA MÁS DETALLES Y ÚLTIMAS NOVEDADES
POUR INFORMATION DÉTAILLÉE & NOUVEAUTÉS
FOR DETAILED INFORMATION & NEW PRODUCTS
FÜR WEITERE DETAILS UND NEUHEITEN

TIPOS DE CABEZAL

TYPES DE TÊTIÈRE
TYPES OF HEADREST
KOPFTEIL

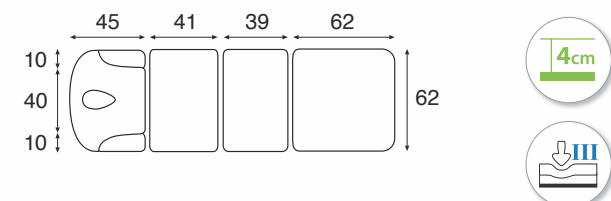

Standard: 62 x 192 cm. (M45)

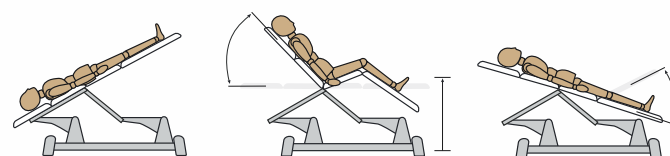

C5978

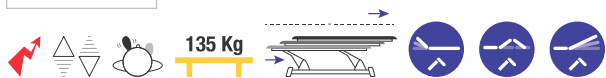

TIPOS DE RESPALDO

TYPES DE DOSSIER
TYPES OF BACKREST
OPTIONEN RÜCKENTEIL

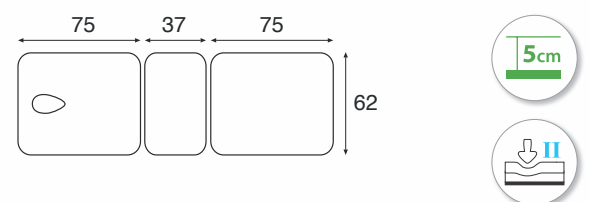

Standard: 62 x 192 cm. (M45)



C5905

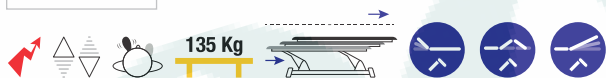

41 Blanc	42 Gris	43 Noir	44 Jonquille	45 Banane	46 Ocre	47 Rose	48 Clémentine	49 Coquelicot	50 Framboise	51 Iris	NEW 30 Cherry	
52 Lilas	53 Roi	54 Bleuets	55 Ciel	56 Sanitaire	57 Java	58 Kiwi	59 Gazon	60 Celadon	61 Crème	62 Marron	31 Smoke	32 Anthracite



C5978

C5905

TIPOS DE CABEZAL

TYPES DE TÊTIÈRE
TYPES OF HEADREST
KOPFTEIL

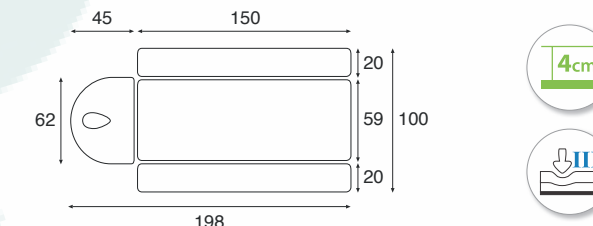

Standard: 100 x 198 cm. (M86)



C5506

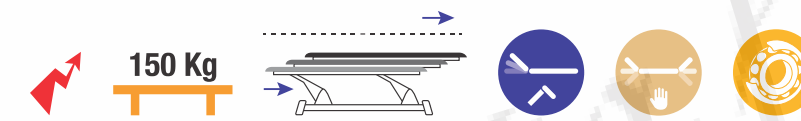

41 Blanc	42 Gris	43 Noir	44 Jonquille	45 Banane	46 Ocre	47 Rose	48 Clémentine	49 Coquelicot	50 Framboise	51 Iris	NEW 30 Cherry	
52 Lilas	53 Roi	54 Bleuets	55 Ciel	56 Sanitaire	57 Java	58 Kiwi	59 Gazon	60 Celadon	61 Crème	62 Marron	31 Smoke	32 Anthracite

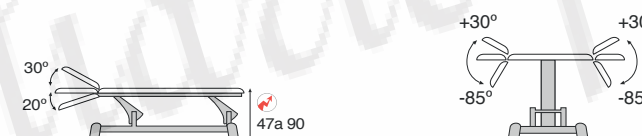

C5506

VISTA FRONTAL DEL TAPIZADO
VUE FRONTALE
FRONT VIEW
FRONTANSICHT DEL LIEGE

MOVIMIENTOS DEL TAPIZADO
MOUVEMENTS DES PLATEAUX
TILTS & MOVEMENTS
BEWEGUNGEN DER SEGMENTE



www.ecopostural.com

PARA MÁS DETALLES Y ÚLTIMAS NOVEDADES
 POUR INFORMATION DÉTAILLÉE & NOUVEAUTÉS
 FOR DETAILED INFORMATION & NEW PRODUCTS
 FÜR WEITERE DETAILS UND NEUHEITEN



C7979



C5579

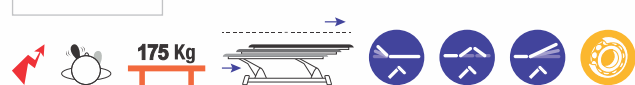

C7579



C5779

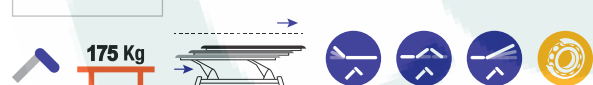

C7779

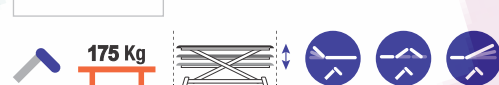

TIPOS DE CABEZAL

TYPES DE TÊTIÈRE
 TYPES OF HEADREST
 KOPFTEIL

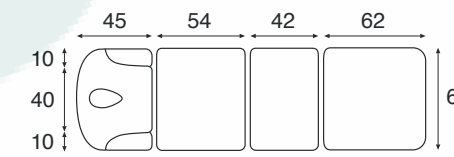
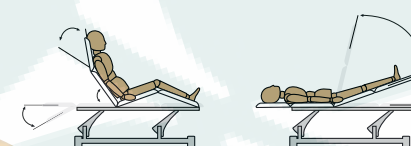

Standard: 62 x 207 cm. (M48)



C5579

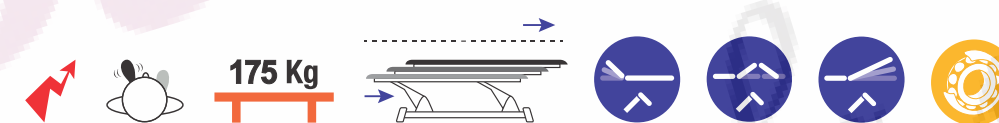

41 Blanc	42 Gris	43 Noir	44 Jonquille	45 Banane	46 Ocre	47 Rose	48 Clémentine	49 Coquelicot	50 Framboise	51 Iris	NEW	30 Cherry
52 Lilas	53 Roi	54 Bleuets	55 Ciel	56 Sanitaire	57 Java	58 Kiwi	59 Gazon	60 Celadon	61 Crème	62 Marron	31 Smoke	32 Anthracite

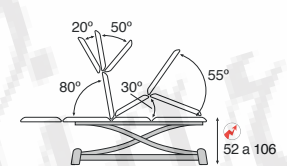

C7979

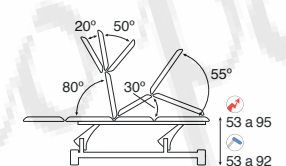

C5579 / C5779

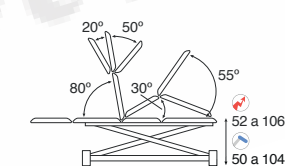

C7579 / C7779

TIPOS DE CABEZAL

TYPES DE TÊTIÈRE
TYPES OF HEADREST
KOPFTEILE

STANDARD



T 03

BAJO PEDIDO / SUR DEMANDE / ON ORDER / AUF ANFRAGE



T 04



T 01



T 02



C5532

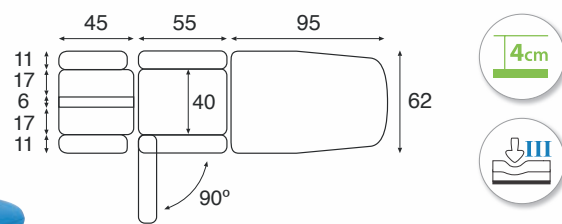
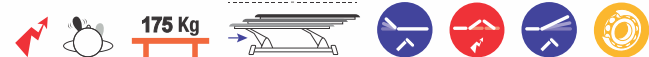

Standard: 62 x 200 cm. (M47)

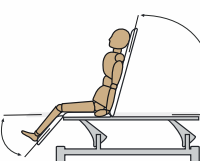
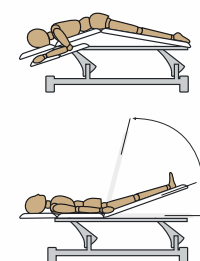

C5732



41 Blanc	42 Gris	43 Noir	44 Jonquille	45 Banane	46 Ocre	47 Rose	48 Clémentine	49 Coquelicot	50 Framboise	51 Iris	NEW 30 Cherry	
52 Lilas	53 Roi	54 Bleuets	55 Ciel	56 Sainfoin	57 Java	58 Kiwi	59 Gazon	60 Celadon	61 Crème	62 Marron	31 Smoke	32 Anthracite

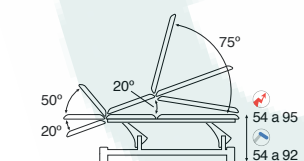

C5532 / C5732

TIPOS DE CABEZAL

TYPES DE TÊTIÈRE
TYPES OF HEADREST
KOPFTEIL

STANDARD



T 07



T 08



T 09



T 10



T 11



T 12



C5949

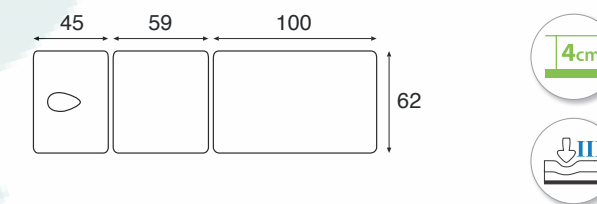

Standard: 62 x 207 cm. (M48)

41 Blanc	42 Gris	43 Noir	44 Jonquille	45 Banane	46 Ocre	47 Rose	48 Clémentine	49 Coquelicot	50 Framboise	51 Iris	NEW 30 Cherry	
52 Lilas	53 Roi	54 Bleuets	55 Ciel	56 Sainfoin	57 Java	58 Kiwi	59 Gazon	60 Celadon	61 Crème	62 Marron	31 Smoke	32 Anthracite

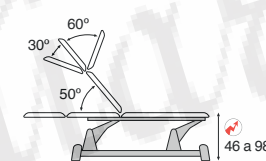

C5949



C5910



C7910



C5510

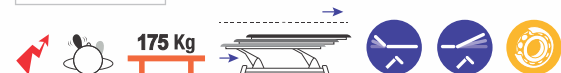

C7510



C5710



C7710



TIPOS DE CABEZAL

TYPES DE TÊTIÈRE
TYPES OF HEADREST
KOPFTEIL

STANDARD



T 10

BAJO PEDIDO / SUR DEMANDE / ON ORDER / AUF ANFRAGE



T 11



T 12



T 07



T 08



T 09

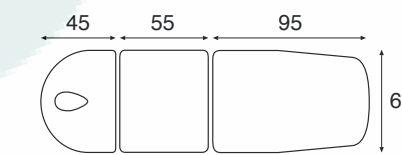
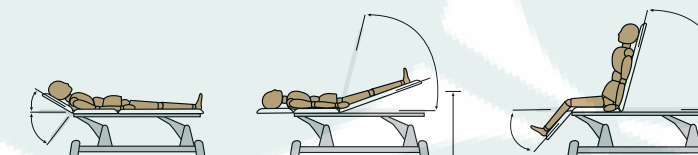

Standard: 62 x 200 cm. (M47)



C5910



41 Blanc	42 Gris	43 Noir	44 Jonquille	45 Banane	46 Ocre	47 Rose	48 Clémentine	49 Coquelicot	50 Framboise	51 Iris	NEW 30 Cherry	
52 Lilas	53 Roi	54 Bleuets	55 Ciel	56 Sanitaire	57 Java	58 Kiwi	59 Gazon	60 Celadon	61 Crème	62 Marron	31 Smoke	32 Anthracite

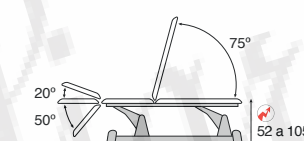

C5910



C7910

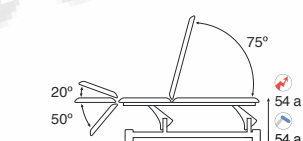

C5510 / C5710

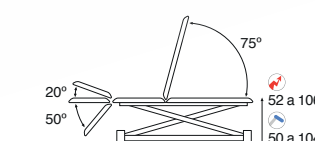

C7510 / C7710



C5593

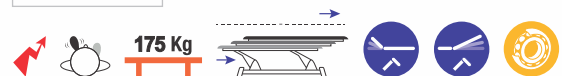

C5793

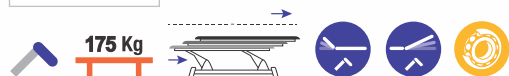

C5596

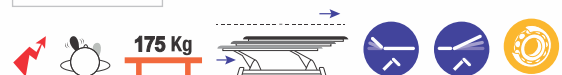

C5796

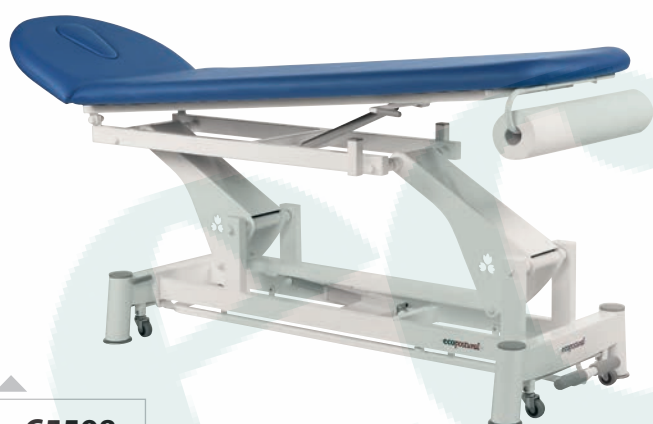
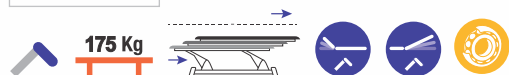

C5598

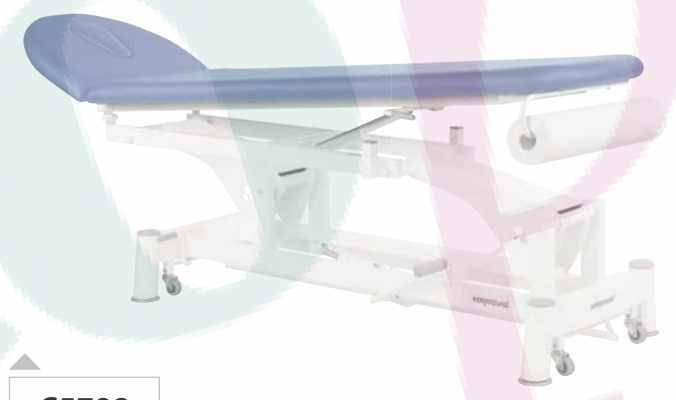
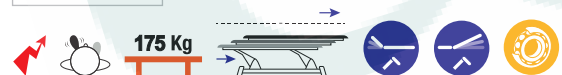

C5798

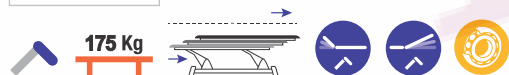

C5593 C5793	STANDARD	BAJO PEDIDO / SUR DEMANDE / ON ORDER / AUF ANFRAGE	
	T 03	T 04 T 01 T 02	
C5596 C5796	STANDARD	BAJO PEDIDO / SUR DEMANDE / ON ORDER / AUF ANFRAGE	
	T 05	T 06	
C5598 C5798	STANDARD	BAJO PEDIDO / SUR DEMANDE / ON ORDER / AUF ANFRAGE	
	T 10	T 11 T 12 T 07 T 08 T 09	



C5798

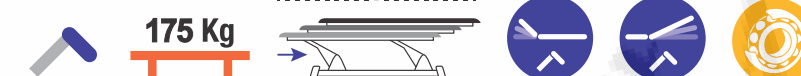

41 Blanc	42 Gris	43 Noir	44 Jonquille	45 Banane	46 Ocre	47 Rose	48 Clémentine	49 Coquelicot	50 Framboise	51 Iris	NEW 30 Cherry	
52 Lilas	53 Roi	54 Bleuets	55 Ciel	56 Sanitaire	57 Java	58 Kivi	59 Gazon	60 Celadon	61 Crème	62 Marron	31 Smoke	32 Anthracite

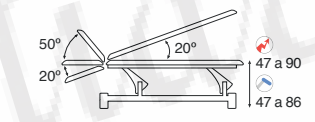

C5593 / C5793
C5596 / C5796
C5598 / C5798



C5935



C7935



C5535

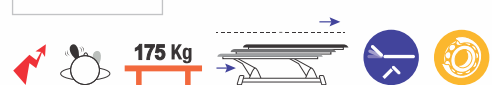

C7535



C5735

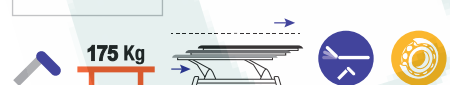

C7735



TIPOS DE CABEZAL

TYPES DE TÊTIÈRE
TYPES OF HEADREST
KOPFTEIL

STANDARD



T 05

BAJO PEDIDO / SUR DEMANDE / ON ORDER / AUF ANFRAGE



T 06

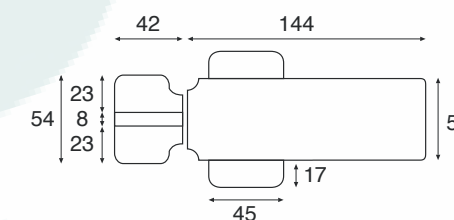
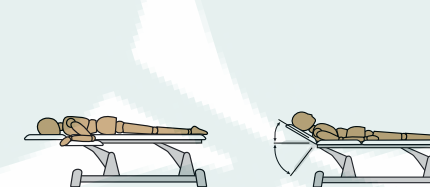

Standard: 50 x 188 cm. (M14)



C5935



41 Blanc	42 Gris	43 Noir	44 Jonquille	45 Banane	46 Ocre	47 Rose	48 Clémentine	49 Coquelicot	50 Framboise	51 Iris	NEW	30 Cherry
52 Lilas	53 Roi	54 Bleuets	55 Ciel	56 Sanitaire	57 Java	58 Kiwi	59 Gazon	60 Celadon	61 Crème	62 Marron	31 Smoke	32 Anthracite



C5935



C7935

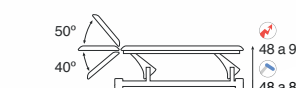

C5535 / C5735



C7535 / C7735



C5946



C7946



C5546

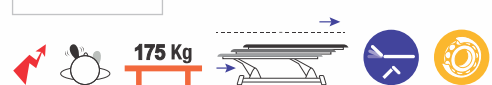

C7546

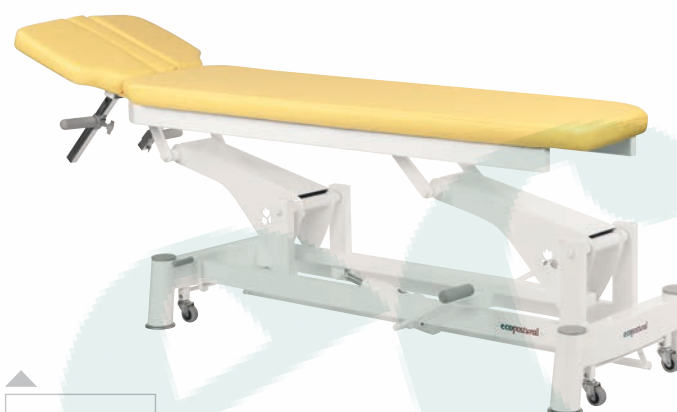

C5746

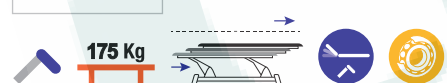

C7746



TIPOS DE CABEZAL
TYPES DE TÊTIÈRE
TYPES OF HEADREST
KOPFTEIL

STANDARD

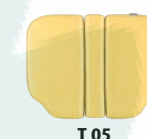

BAJO PEDIDO / SUR DEMANDE / ON ORDER / AUF ANFRAGE

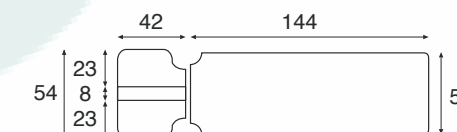
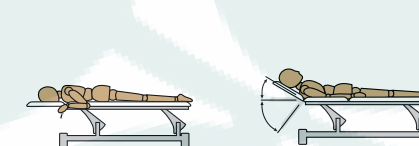
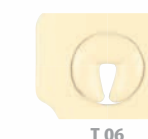

Standard: 50 x 188 cm. (M14)

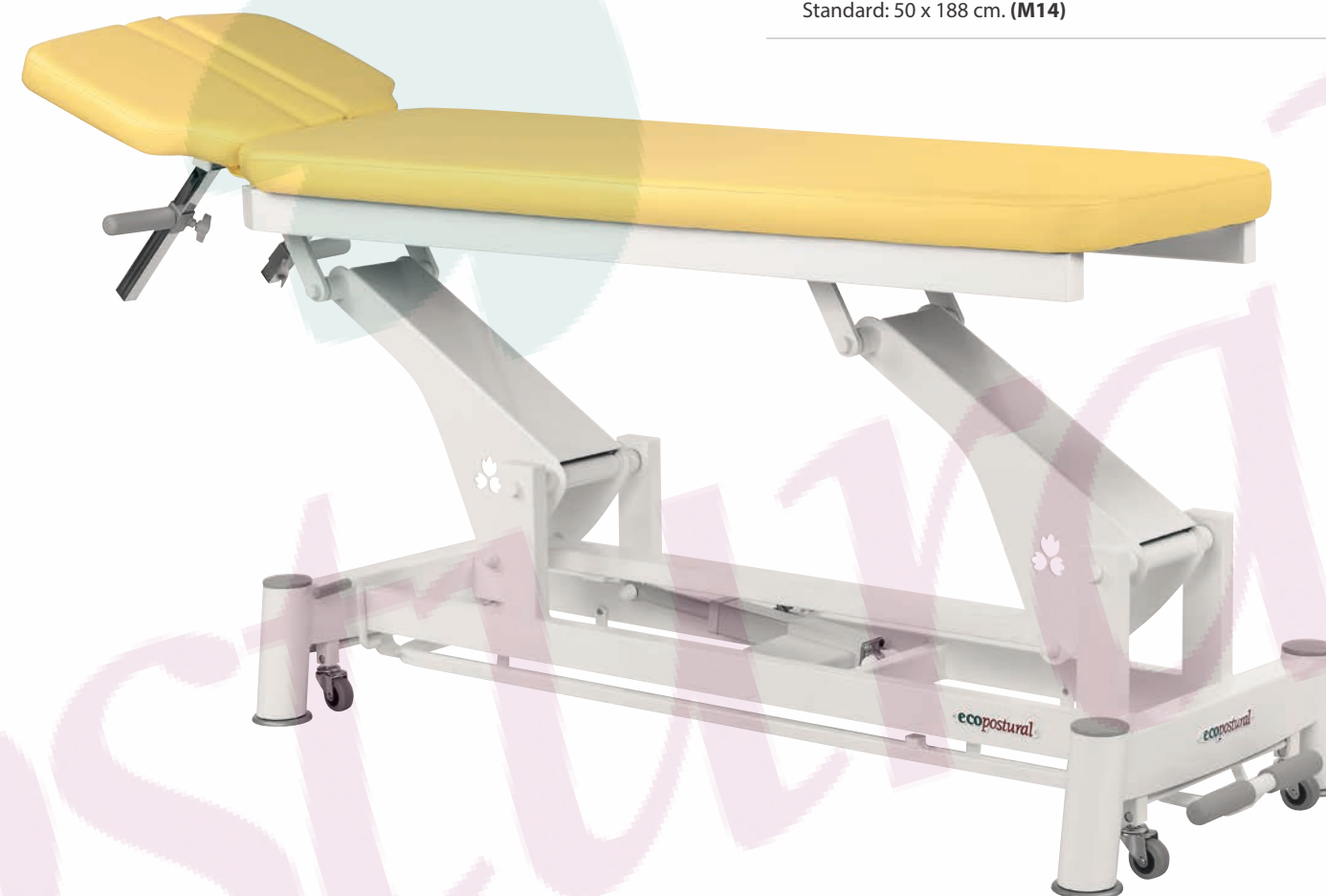

C5546

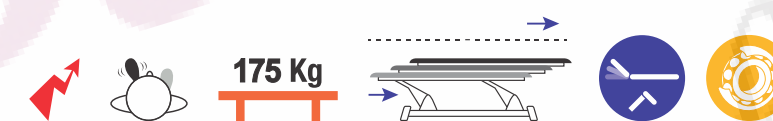

41 Blanc	42 Gris	43 Noir	44 Jonquille	45 Banane	46 Ocre	47 Rose	48 Clémentine	49 Coquelicot	50 Framboise	51 Iris	NEW 30 Cherry	
52 Lilas	53 Roi	54 Bleuet	55 Ciel	56 Sanitaire	57 Java	58 Kivi	59 Gazon	60 Celadon	61 Crème	62 Marron	31 Smoke	32 Anthracite



C5946



C7946

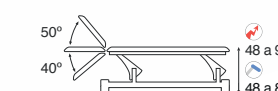

C5546 / C5746

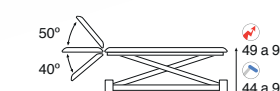

C7546 / C7746



C5944



C7944



C5544

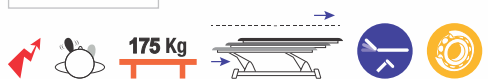

C7544



C5744

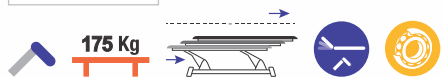

C7744

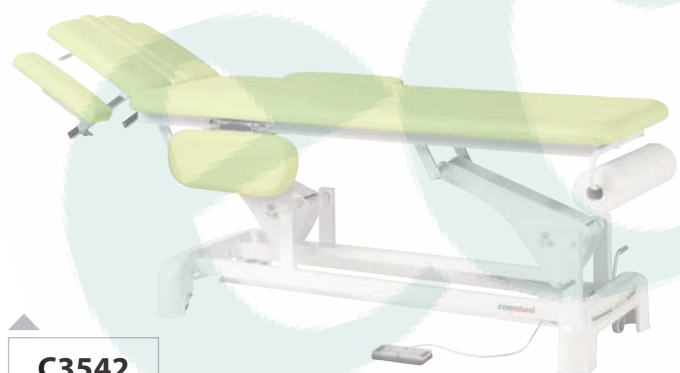

C3542



BAJO PEDIDO / SUR DEMANDE / ON ORDER / AUF ANFRAGE



OPCIÓN PIE CON REDUCCIÓN
DÉCROCHEMENT PLATEAU PIEDS · TAPERED FEET SECTION
OPTION BEINTEIL REDUZIERT

TIPOS DE CABEZAL
TYPES DE TÊTIÈRE
TYPES OF HEADREST
KOPFTEIL

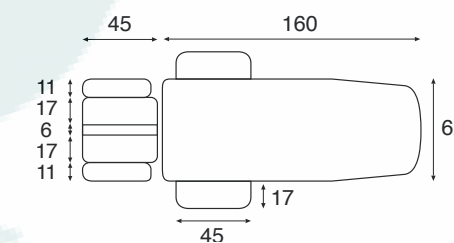

Standard: 62 x 207 cm. (M48)



C3542

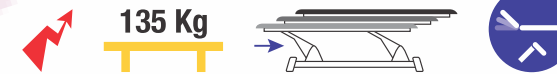

41 Blanc	42 Gris	43 Noir	44 Jonquille	45 Banane	46 Ocre	47 Rose	48 Clémentine	49 Coquelicot	50 Framboise	51 Iris	NEW	30 Cherry
52 Lilas	53 Roi	54 Bleuets	55 Ciel	56 Sanitaire	57 Jara	58 Kiwi	59 Gazon	60 Celadon	61 Crème	62 Marron	31 Smoke	32 Anthracite



C5944



C7944

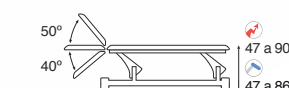

**C5544 / C5744
C3542**

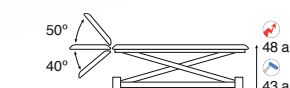

C7544 / C7744



C5943



C7943



C5543

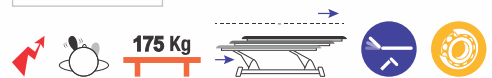

C7543



C5743

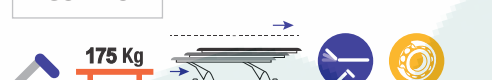

C7743



BAJO PEDIDO / SUR DEMANDE / ON ORDER / AUF ANFRAGE

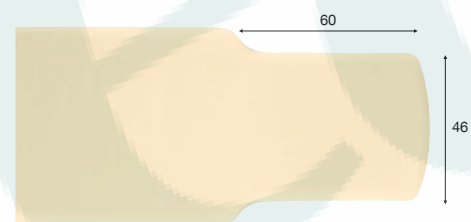

OPCIÓN PIE CON REDUCCIÓN
DÉCROCHEMENT PLATEAU PIEDS · TAPERED FEET SECTION
OPTION BEINTEIL REDUZIERT



DETALLE REDUCCIÓN
DÉTAIL DU DÉCROCHEMENT
DETAIL OF THE TOP NARROWING
DETAIL REDUKTION

TIPOS DE CABEZAL
TYPES DE TÊTIÈRE
TYPES OF HEADREST
KOPFTEIL

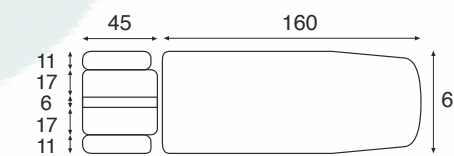

Standard: 62 x 207 cm. (M48)



C7943



41 Blanc	42 Gris	43 Noir	44 Jonquille	45 Banane	46 Ocre	47 Rose	48 Clémentine	49 Coquelicot	50 Framboise	51 Iris	NEW 30 Cherry
52 Lilas	53 Roi	54 Bleuets	55 Ciel	56 Sanitaire	57 Java	58 Kiwi	59 Gazon	60 Celadon	61 Crème	62 Marron	31 Smoke 32 Anthracite



C5943



C7943

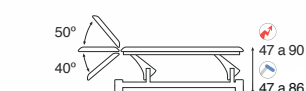

C5543 / C5743

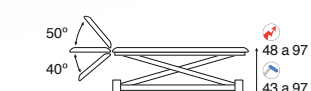

C7543 / C7743



C5924



C7924



C5524

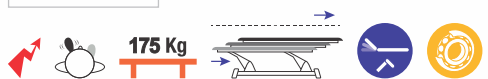

C7524



C5724

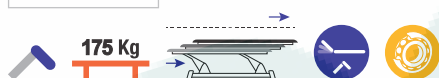

C7724



BAJO PEDIDO / SUR DEMANDE / ON ORDER / AUF ANFRAGE

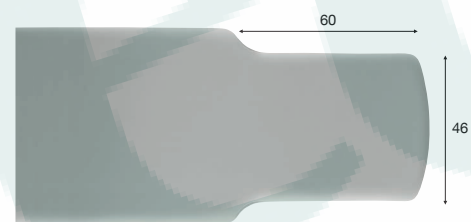

OPCIÓN PIE CON REDUCCIÓN
DÉCROCHEMENT PLATEAU PIEDS · TAPERED FEET SECTION
OPTION BEINTEIL REDUZIERT



DETALLE REDUCCIÓN
DÉTAIL DU DÉCROCHEMENT
DETAIL OF THE TOP NARROWING
DETAIL REDUKTION

TIPOS DE CABEZAL

TYPES DE TÊTIÈRE
TYPES OF HEADREST
KOPFTEIL

STANDARD



T 10

BAJO PEDIDO / SUR DEMANDE / ON ORDER / AUF ANFRAGE



T 11



T 12



T 07



T 08



T 09

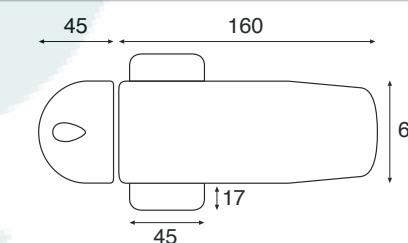
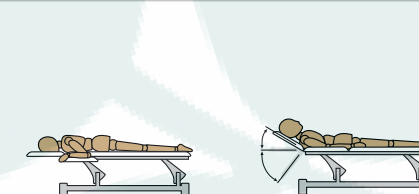

Standard: 62 x 207 cm. (M48)



C5524

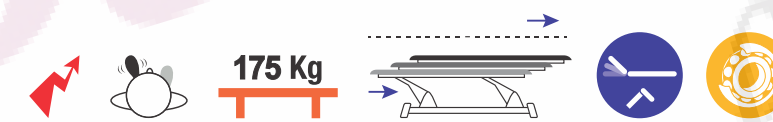

41 Blanc	42 Gris	43 Noir	44 Jonquille	45 Banane	46 Ocre	47 Rose	48 Clémentine	49 Coquelicot	50 Framboise	51 Iris	NEW 30 Cherry	
52 Lilas	53 Roi	54 Bleuets	55 Ciel	56 Sanitaire	57 Java	58 Kiwi	59 Gazon	60 Celadon	61 Crème	62 Marron	31 Smoke	32 Anthracite



C5924



C7924

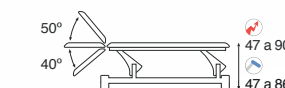

C5524 / C5724

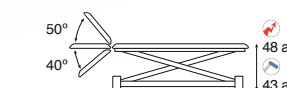

C7524 / C7724



C5928



C7928



C5528

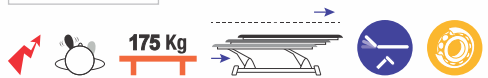

C7528

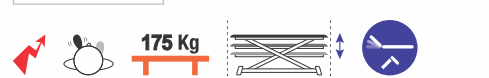

C5728

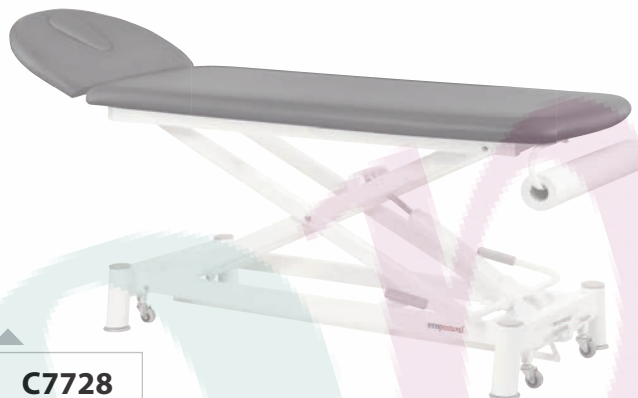
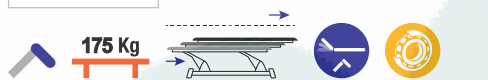

C7728



BAJO PEDIDO / SUR DEMANDE / ON ORDER / AUF ANFRAGE

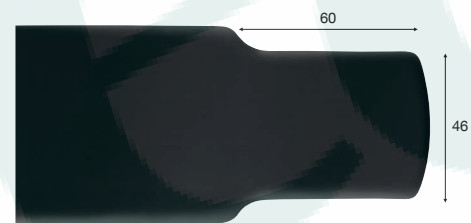

OPCIÓN PIE CON REDUCCIÓN
DÉCROCHEMENT PLATEAU PIEDS · TAPERED FEET SECTION
OPTION BEINTEIL REDUZIERT



DETALLE REDUCCIÓN
DÉTAIL DU DÉCROCHEMENT
DETAIL OF THE TOP NARROWING
DETAIL REDUKTION

TIPOS DE CABEZAL
TYPES DE TÊTIÈRE
TYPES OF HEADREST
KOPFTEIL

STANDARD

BAJO PEDIDO / SUR DEMANDE / ON ORDER / AUF ANFRAGE



T 10



T 11



T 12



T 07



T 08



T 09

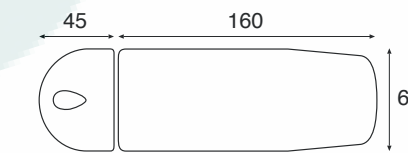
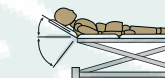

Standard: 62 x 207 cm. (M48)



C7728



41 Blanc	42 Gris	43 Noir	44 Jonquille	45 Banane	46 Ocre	47 Rose	48 Clémentine	49 Coquelicot	50 Framboise	51 Iris	NEW	30 Cherry
52 Lilas	53 Roi	54 Bleuets	55 Ciel	56 Sanitaire	57 Java	58 Kiwi	59 Gazon	60 Celadon	61 Crème	62 Marron	31 Smoke	32 Anthracite

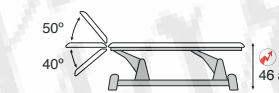

C5928

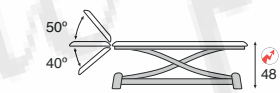

C7928

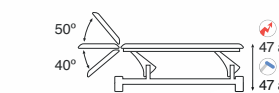

C5528 / C5728

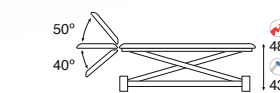

C7528 / C7728

TIPOS DE CABEZAL

TYPES DE TÊTIÈRE
TYPES OF HEADREST
KOPFTEILE

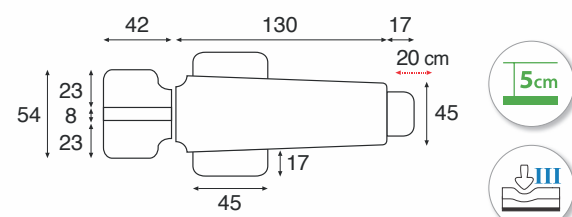

Standard: 55 x 188 cm. (M24)

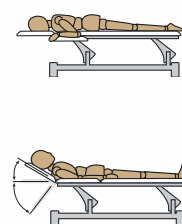

C3545

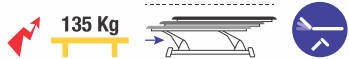

TIPOS DE RESPALDO

TYPES DE DOSSIER
TYPES OF BACKREST
OPTIONEN RÜCKENTEIL

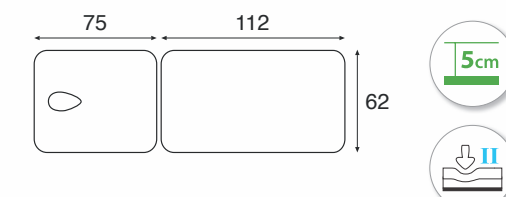

Standard: 62 x 188 cm. (M44)
Opcional: 70 x 188 cm. (M64)

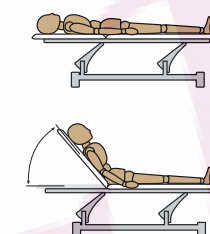

C3741

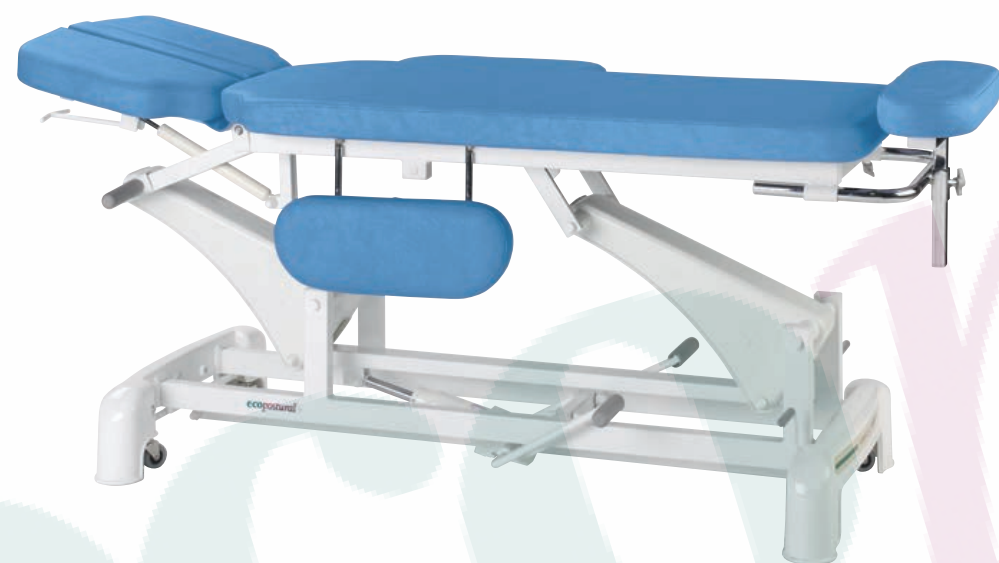

C3745



C3541



41	Blanc	42	Gris	43	Noir	44	Jonquille	45	Banane	46	Ocre	47	Rose	48	Clémentine	49	Coquelicot	50	Framboise	51	Iris	NEW	30	Cherry	
52	Lilas	53	Roi	54	Bleuet	55	Ciel	56	Sanitaire	57	Java	58	Kiwi	59	Gazon	60	Celadon	61	Crème	62	Marron	31	Smoke	32	Anthracte

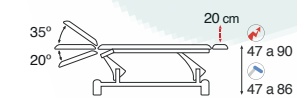

C3545 / C3745

41	Blanc	42	Gris	43	Noir	44	Jonquille	45	Banane	46	Ocre	47	Rose	48	Clémentine	49	Coquelicot	50	Framboise	51	Iris	NEW	30	Cherry	
52	Lilas	53	Roi	54	Bleuet	55	Ciel	56	Sanitaire	57	Java	58	Kiwi	59	Gazon	60	Celadon	61	Crème	62	Marron	31	Smoke	32	Anthracte

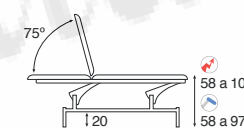

C3541 / C3741



ecopostural
mobiliario para la salud.

ESPECIALIDADES

SPÉCIALITÉS · SPECIALITY · SPEZIALLIEGEN / STUHL



PRODUCTO FABRICADO EN ESPAÑA
PRODUIT FABRIQUÉ EN ESPAGNE
PRODUCT MADE IN SPAIN
PRODUKT HERGESTELLT IN SPANIEN



www.ecopostural.com
PARA MÁS DETALLES Y ÚLTIMAS NOVEDADES
POUR INFORMATION DÉTAILLÉE & NOUVEAUTÉS
FOR DETAILED INFORMATION & NEW PRODUCTS
FÜR WEITERE DETAILS UND NEUHEITEN

ESPECIALIDADES
SPECIALITÉS
SPECIALITIES
SPEZIALLIEGEN / STUHL

ESPECIALIDADES
SPECIALITÉS
SPECIALITIES
SPEZIALLIEGEN / STUHL



C5981

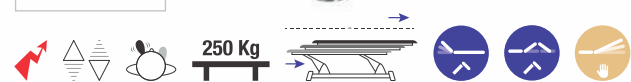

C7981

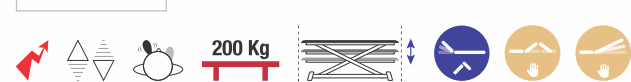

C5581

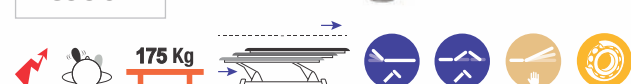

C7581

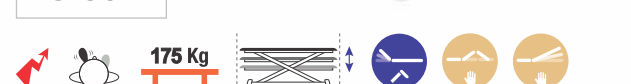

C5781



C7781



C4581



BAJO PEDIDO / SUR DEMANDE / ON ORDER / AUF ANFRAGE

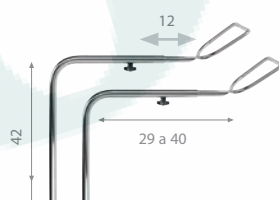

A4707

OPCIÓN ESTRIBOS
OPTION ÉTRIERS · STIRRUPS OPTIONALLY AVAILABLE
OPTION FERSENSTÜTZEN

TIPOS DE RESPALDO
TYPES DE DOSSIER
TYPES OF BACKREST
OPTIONEN RÜCKENTEILE

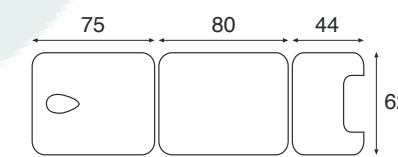
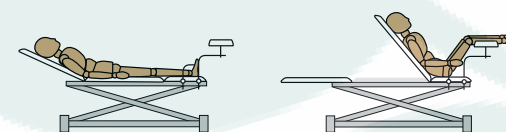

Standard: 62 x 200 cm. (M47)
Opcional: 70 x 200 cm. (M67)



C7581



41 Blanc	42 Gris	43 Noir	44 Jonquille	45 Banane	46 Ocre	47 Rose	48 Clémentine	49 Coquelicot	50 Framboise	51 Iris	NEW 30 Cherry	
52 Lilas	53 Roi	54 Bleuets	55 Ciel	56 Sanitaire	57 Java	58 Kiwi	59 Gazon	60 Celadon	61 Crème	62 Marron	31 Smoke	32 Anthracite

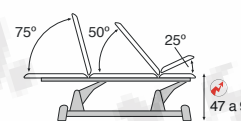

C5981

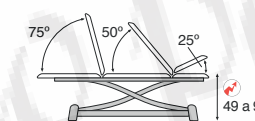

C7981

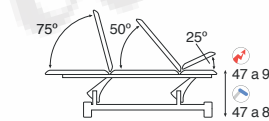

C5581 / C5781

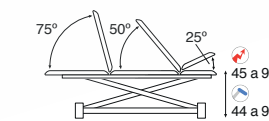

C7581 / C7781

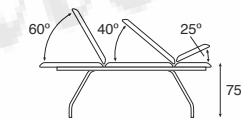

C4581

ESPECIALIDADES
SPECIALITÉS
SPEZIALLIEGEN / STUHL

ESPECIALIDADES
SPECIALITÉS
SPEZIALLIEGEN / STUHL



C5914H



14 cm.



C5914



14 cm.



C5514

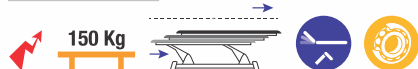

14 cm.



C5714

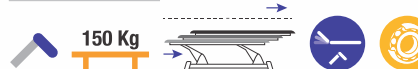

14 cm.

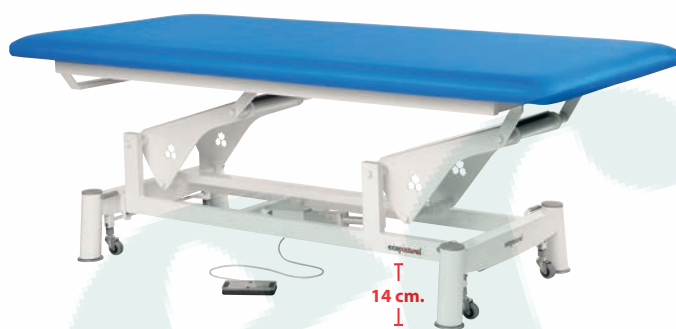

C5504



14 cm.



C4517



135 Kg

STANDARD BAJO PEDIDO / SUR DEMANDE / ON ORDER / AUF ANFRAGE

C5914H
C5914
C5514
C5714

T 15 T 13

Standard: 100 x 185 cm. (M82)
Opcional: 120 x 185 cm. (M92)
Opcional: 120 x 200 cm. (M97)

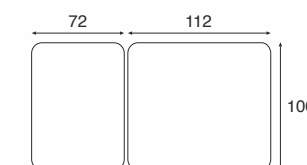

5cm



C5504
C5704
C4517

Standard: 100 x 200 cm. (M87)
Opcional: 120 x 200 cm. (M97)



5cm



C5914H



41 Blanc	42 Gris	43 Noir	44 Jonquille	45 Banane	46 Ocre	47 Rose	48 Clémentine	49 Coquelicot	50 Framboise	51 Iris	NEW 30 Cherry	
52 Lilas	53 Roi	54 Bleuets	55 Ciel	56 Sanitaire	57 Java	58 Kiwi	59 Gazon	60 Celadon	61 Crème	62 Marron	31 Smoke	32 Anthracite

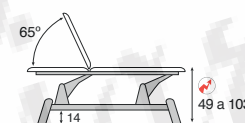

C5914H / C5914



C5514 / C5714

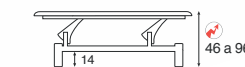

C5504 / C5704



C4517

TIPOS DE RESPALDO
TYPES DE DOSSIER
TYPES OF BACKREST
OPTIONEN RÜCKENTEILE



TIPOS DE RESPALDO
TYPES DE DOSSIER
TYPES OF BACKREST
OPTIONEN RÜCKENTEILE



C3548

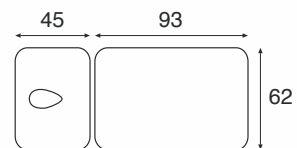
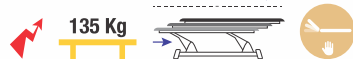

Standard: 62 x 140 cm. (M40)

CAMILLAS CORTAS PARA PEDIATRÍA
TABLES COURTES POUR PÉDIATRIE
SHORTER TABLES FOR PEDIATRICS
KÜRZERE THERAPIELIEGEN FÜR PÄDIATRIE



C3700

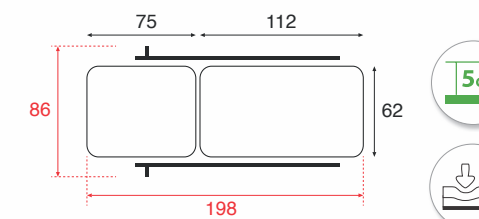

Standard: 62 x 188 cm. (M44)



Ø125
RUEDA DIRECCIONABLE
ROUES DIRECTIONNELLES
DIRECTIONAL CASTORS
RÄDERGESTELL
RICHTUNGSWEISEND



Ø125
RUEDA CON FRENO
ROUES AVEC FREIN
CASTORS WITH BRAKE
RÄDERGESTELL
MIT BREMSSTOPPER



C3748

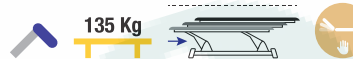

C4548



C4501

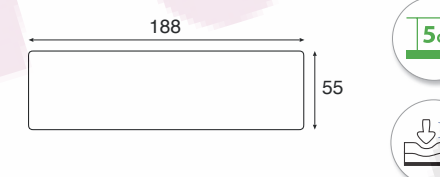

Standard: 55 x 188 cm. (M24)



PEDIDO MÍNIMO
CONSULTAR ECOPOSTURAL
QUANTITÉ MINIMUM À COMMANDER
CONSULTER ECOPOSTURAL
MINIMUM QUANTITY TO ORDER
CONTACT ECOPOSTURAL
MINDESTMENGE ERFORDERLICH
BEI ECOPOSTURAL ANFRAGEN

41 Blanc	42 Gris	43 Noir	44 Jonquille	45 Banane	46 Ocre	47 Rose	48 Clémentine	49 Coquelicot	50 Framboise	51 Iris	NEW 30 Cherry
52 Lilas	53 Roi	54 Bleuets	55 Ciel	56 Sanitaire	57 Java	58 Kiwi	59 Gazon	60 Celadon	61 Crème	62 Marron	31 Smoke 32 Anthracite

41 Blanc	42 Gris	43 Noir	44 Jonquille	45 Banane	46 Ocre	47 Rose	48 Clémentine	49 Coquelicot	50 Framboise	51 Iris	NEW 30 Cherry
52 Lilas	53 Roi	54 Bleuets	55 Ciel	56 Sanitaire	57 Java	58 Kiwi	59 Gazon	60 Celadon	61 Crème	62 Marron	31 Smoke 32 Anthracite



C3548/ C3748

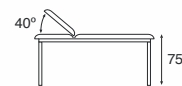

C4548

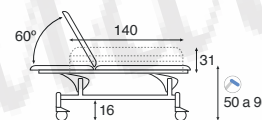

C3700

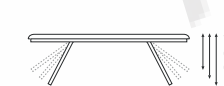

C4501

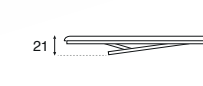

C4501

PLEGADO · REPLIÉ · FLAT FOLD · KLAPPBAR



TIPOS DE RESPALDO
TYPES DE DOSSIER
TYPES OF BACKREST
OPTIONEN RÜCKENTEILE

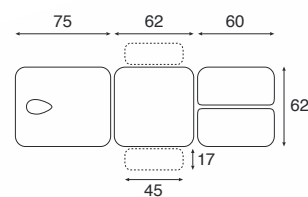

Standard: 62 x 198 cm. (M46)
Standard: 70 x 198 cm. (M66)



TIPOS DE RESPALDO
TYPES DE DOSSIER
TYPES OF BACKREST
OPTIONEN RÜCKENTEILE

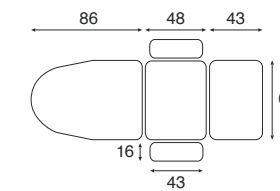
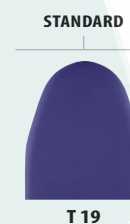

Standard: 62 x 182 cm. (M41)



ESPECIALIDADES
SPECIALITÉS
SPECIALITIES
SPEZIALLIEGEN / STUHL

ESPECIALIDADES
SPECIALITÉS
SPECIALITIES
SPEZIALLIEGEN / STUHL



C5539

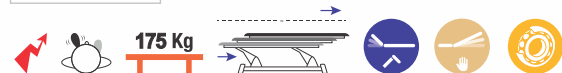

C5538

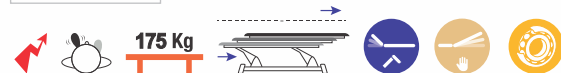

C3569



C3769



C5739

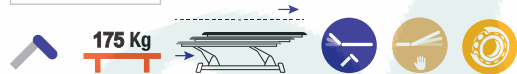

C5738

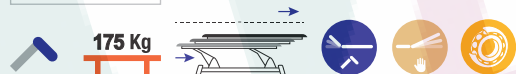

C4369

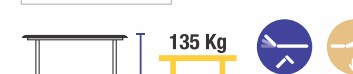

A4458

DE SERIE EN ESTOS SILLONES
DE SÉRIE SUR CES FAUTEUILS
INCLUDED AS STANDARD IN THESE CHAIRS
SERIENMÄSSIG BEI DIESEN STÜHLEN

41 Blanc	42 Gris	43 Noir	44 Jonquille	45 Banane	46 Ocre	47 Rose	48 Clémentine	49 Coquelicot	50 Framboise	51 Iris	NEW 30 Cherry	
52 Lilas	53 Roi	54 Bleuets	55 Ciel	56 Sanitaire	57 Java	58 Kiwi	59 Gazon	60 Celadon	61 Crème	62 Marron	31 Smoke	32 Anthracite

41 Blanc	42 Gris	43 Noir	44 Jonquille	45 Banane	46 Ocre	47 Rose	48 Clémentine	49 Coquelicot	50 Framboise	51 Iris	NEW 30 Cherry	
52 Lilas	53 Roi	54 Bleuets	55 Ciel	56 Sanitaire	57 Java	58 Kiwi	59 Gazon	60 Celadon	61 Crème	62 Marron	31 Smoke	32 Anthracite



C5539 / C5538
C5739 / C5738

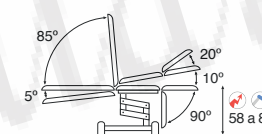

C3569 / C3769



C4369



C3567

135 Kg



C3767

135 Kg



C4367

135 Kg



C3568

135 Kg



C3768

135 Kg



C4368

135 Kg

TIPOS DE RESPALDO
TYPES DE DOSSIER
TYPES OF BACKREST
OPTIONEN RÜCKENTEILE

STANDARD BAJO PEDIDO / SUR DEMANDE / ON ORDER / AUF ANFRAGE

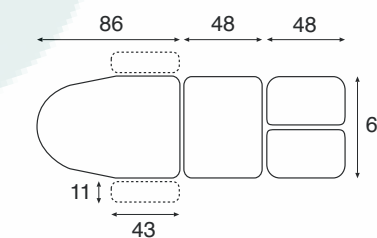

Standard: 62 x 188 cm. (M44)



C4367

135 Kg

41 Blanc	42 Gris	43 Noir	44 Jonquille	45 Banane	46 Ocre	47 Rose	48 Clémentine	49 Coquelicot	50 Framboise	51 Iris	NEW 30 Cherry	
52 Lilas	53 Roi	54 Bleuets	55 Ciel	56 Sanitaire	57 Java	58 Kivi	59 Gazon	60 Celadon	61 Crème	62 Marron	31 Smoke	32 Anthracite



C3567 / C3767
C3568 / C3768

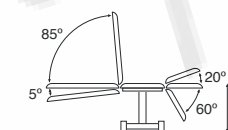

C4367
C4368



C3565

135 Kg



C3566

135 Kg



C3765

135 Kg



C3766

135 Kg



C4365

135 Kg



C4366

135 Kg

TIPOS DE RESPALDO
TYPES DE DOSSIER
TYPES OF BACKREST
OPTIONEN RÜCKENTEILE

STANDARD BAJO PEDIDO / SUR DEMANDE / ON ORDER / AUF ANFRAGE

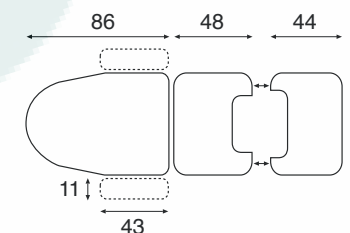

Standard: 62 x 182 cm. (M41)



C3566

135 Kg

A4458

DE SERIE EN ESTOS SILLONES
DE SÉRIE SUR CES FAUTEUILS
INCLUDED AS STANDARD IN THESE CHAIRS
SERIENMÄSSIG BEI DIESEN STÜHLEN

41 Blanc	42 Gris	43 Noir	44 Jonquille	45 Banane	46 Ocre	47 Rose	48 Clémentine	49 Coquelicot	50 Framboise	51 Iris	NEW 30 Cherry	
52 Lilas	53 Roi	54 Bleuets	55 Ciel	56 Sanitaire	57 Java	58 Kiwi	59 Gazon	60 Celadon	61 Crème	62 Marron	31 Smoke	32 Anthracite

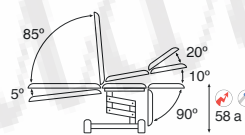

C3565 / C3765
C3566 / C3766

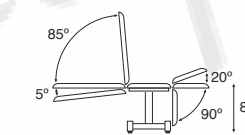

C4365
C4366

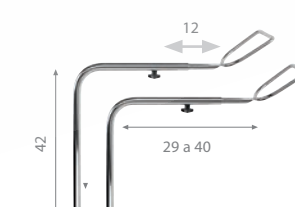

A4707

OPCIÓN ESTRIBOS
OPTION ÉTRIERS · STIRRUPS OPTIONALLY AVAILABLE
OPTION FERSENSTÜTZEN





C3571

135 Kg



C3572

135 Kg



C3771

135 Kg



C3772

135 Kg



C4371

135 Kg



C4372

135 Kg

TIPOS DE RESPALDO
TYPES DE DOSSIER
TYPES OF BACKREST
OPTIONEN RÜCKENTEILE

STANDARD BAJO PEDIDO / SUR DEMANDE / ON ORDER / AUF ANFRAGE



T 19



T 18

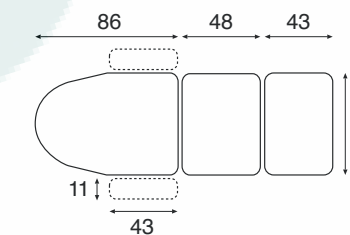

Standard: 62 x 182 cm. (M41)



C3771

135 Kg

A4458

DE SERIE EN ESTOS SILLONES
DE SÉRIE SUR CES FAUTEUILS
INCLUDED AS STANDARD IN THESE CHAIRS
SERIENMÄSSIG BEI DIESEN STÜHLEN

41 Blanc	42 Gris	43 Noir	44 Jonquille	45 Banane	46 Ocre	47 Rose	48 Clémentine	49 Coquelicot	50 Framboise	51 Iris	NEW 30 Cherry	
52 Lilas	53 Roi	54 Bleuets	55 Ciel	56 Sanitaire	57 Java	58 Kiwi	59 Gazon	60 Celadon	61 Crème	62 Marron	31 Smoke	32 Anthracite

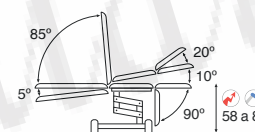

C3571 / C3771
C3572 / C3772

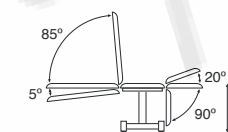

C4371
C4372



ecopostural
mobiliario para la salud.

3 CUERPOS

3 PLANS · 3 SECTION · 3 SEGMENTE



PRODUCTO FABRICADO EN ESPAÑA
PRODUIT FABRIQUÉ EN ESPAGNE
PRODUCT MADE IN SPAIN
PRODUKT HERGESTELLT IN SPANIEN



www.ecopostural.com

PARA MÁS DETALLES Y ÚLTIMAS NOVEDADES
POUR INFORMATION DÉTAILLÉE & NOUVEAUTÉS
FOR DETAILED INFORMATION & NEW PRODUCTS
FÜR WEITERE DETAILS UND NEUHEITEN



TIPOS DE RESPALDO
TYPES DE DOSSIER
TYPES OF BACKREST
OPTIONEN RÜCKENTEILE

C5986
C5985



T 16

BAJO PEDIDO / SUR DEMANDE / ON ORDER / AUF ANFRAGE



T 17

STANDARD

C5959
C5955



T 13

BAJO PEDIDO / SUR DEMANDE / ON ORDER / AUF ANFRAGE



T 14



T 15

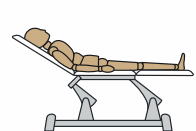

Standard: 62 x 192 cm. (M45)
Opcional: 70 x 192 cm. (M65)

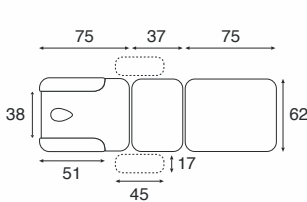

C5986



C5985



C5959



C5955



- | | | | | | | | | | | | | |
|----------|---------|------------|--------------|--------------|---------|---------|---------------|---------------|--------------|-----------|---------------|---------------|
| 41 Blanc | 42 Gris | 43 Noir | 44 Jonquille | 45 Banane | 46 Ocre | 47 Rose | 48 Clémentine | 49 Coquelicot | 50 Framboise | 51 Iris | NEW 30 Cherry | |
| 52 Lilas | 53 Roi | 54 Bleuets | 55 Ciel | 56 Sanitaire | 57 Java | 58 Kiwi | 59 Gazon | 60 Celadon | 61 Crème | 62 Marron | 31 Smoke | 32 Anthracite |

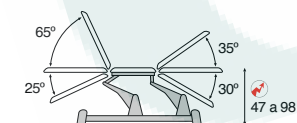

C5986 / C5985
C5959 / C5955

TIPOS DE RESPALDO
TYPES DE DOSSIER
TYPES OF BACKREST
OPTIONEN RÜCKENTEILE

STANDARD



T 13

BAJO PEDIDO / SUR DEMANDE / ON ORDER / AUF ANFRAGE



T 14



T 15

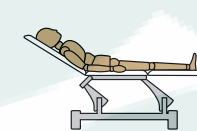

Standard: 62 x 198 cm. (M46)
Opcional: 70 x 198 cm. (M66)

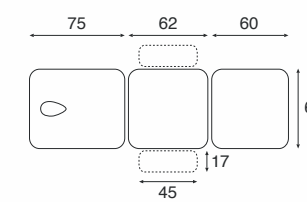

C5556

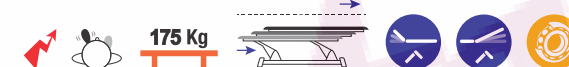

C5557

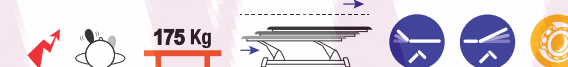

C5756



C5757



- | | | | | | | | | | | | | |
|----------|---------|------------|--------------|--------------|---------|---------|---------------|---------------|--------------|-----------|---------------|---------------|
| 41 Blanc | 42 Gris | 43 Noir | 44 Jonquille | 45 Banane | 46 Ocre | 47 Rose | 48 Clémentine | 49 Coquelicot | 50 Framboise | 51 Iris | NEW 30 Cherry | |
| 52 Lilas | 53 Roi | 54 Bleuets | 55 Ciel | 56 Sanitaire | 57 Java | 58 Kiwi | 59 Gazon | 60 Celadon | 61 Crème | 62 Marron | 31 Smoke | 32 Anthracite |



C5556 / C5557
C5756 / C5757

TIPOS DE RESPALDO
TYPES DE DOSSIER
TYPES OF BACKREST
OPTIONEN RÜCKENTEILE

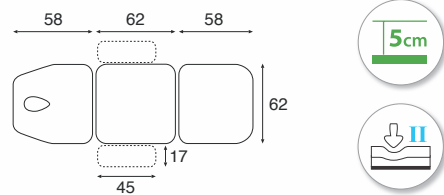
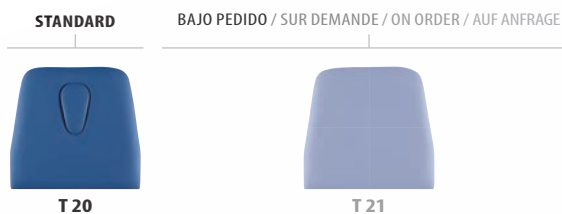

Standard: 62 x 182 cm. (M41)

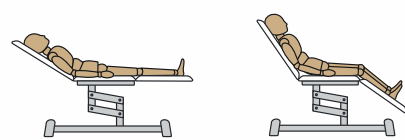

C3516



TIPOS DE RESPALDO
TYPES DE DOSSIER
TYPES OF BACKREST
OPTIONEN RÜCKENTEILE

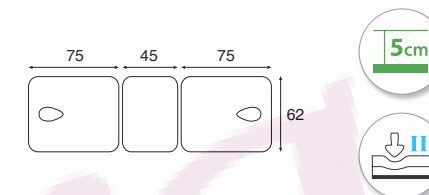

Standard: 62 x 198 cm. (M46)
Opcional: 70 x 198 cm. (M66)



C5547

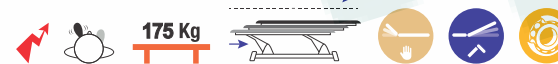

C5747

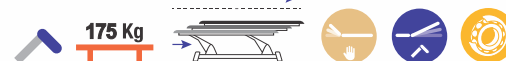

- | | | | | | | | | | | | | |
|----------|---------|------------|--------------|--------------|---------|---------|---------------|---------------|--------------|-----------|---------------|---------------|
| 41 Blanc | 42 Gris | 43 Noir | 44 Jonquille | 45 Banane | 46 Ocre | 47 Rose | 48 Clémentine | 49 Coquelicot | 50 Framboise | 51 Iris | NEW 30 Cherry | |
| 52 Lilas | 53 Roi | 54 Bleuets | 55 Ciel | 56 Sanitaire | 57 Java | 58 Kiwi | 59 Gazon | 60 Celadon | 61 Crème | 62 Marron | 31 Smoke | 32 Anthracite |

- | | | | | | | | | | | | | |
|----------|---------|------------|--------------|--------------|---------|---------|---------------|---------------|--------------|-----------|---------------|---------------|
| 41 Blanc | 42 Gris | 43 Noir | 44 Jonquille | 45 Banane | 46 Ocre | 47 Rose | 48 Clémentine | 49 Coquelicot | 50 Framboise | 51 Iris | NEW 30 Cherry | |
| 52 Lilas | 53 Roi | 54 Bleuets | 55 Ciel | 56 Sanitaire | 57 Java | 58 Kiwi | 59 Gazon | 60 Celadon | 61 Crème | 62 Marron | 31 Smoke | 32 Anthracite |

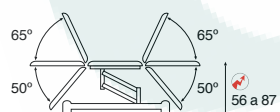

C3515 / C3516



C4576

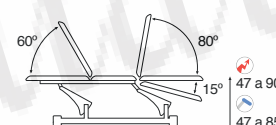

C5547 / C5747



C6103W

135 Kg



C6203

135 Kg



C5903

250 Kg



C7903

200 Kg



C5503

175 Kg



C7503

175 Kg

TIPOS DE RESPALDO
TYPES DE DOSSIER
TYPES OF BACKREST
OPTIONEN RÜCKENTEILE

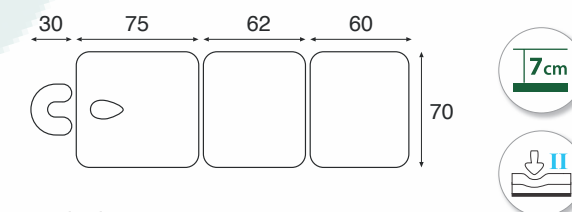

Standard: 70 x 198 cm. (M66)
Opcional: 80 x 198 cm. (M76)



C6203

135 Kg

- | | | | | | | | | | | | | |
|----------|---------|------------|--------------|--------------|---------|---------|---------------|---------------|--------------|-----------|----------------------|---------------|
| 41 Blanc | 42 Gris | 43 Noir | 44 Jonquille | 45 Banane | 46 Ocre | 47 Rose | 48 Clémentine | 49 Coquelicot | 50 Framboise | 51 Iris | NEW 30 Cherry | |
| 52 Lilas | 53 Roi | 54 Bleuets | 55 Ciel | 56 Sanitaire | 57 Java | 58 Kiwi | 59 Gazon | 60 Celadon | 61 Crème | 62 Marron | 31 Smoke | 32 Anthracite |

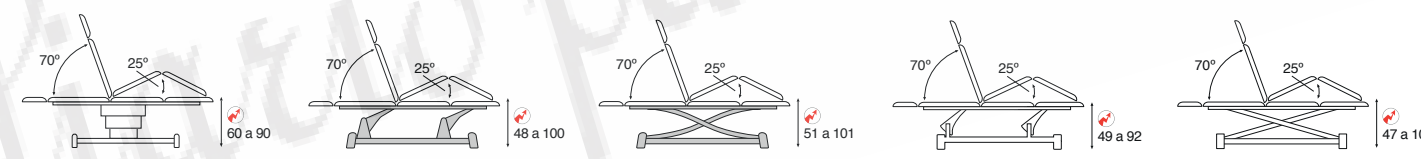

C6103W / C6203 **C5903** **C7903** **C5503** **C7503**



C5526

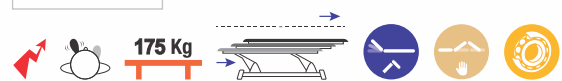

C7926



C5726

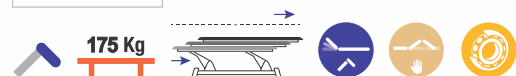

C7526



C3525



C3512

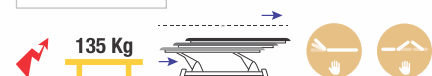

T14 NO DISPONIBLE EN LA C3512
T14 NON DISPONIBILE SUR CE MODELE C3512
T14 NOT AVAILABLE IN THIS MODEL C3512
T14 NICHT VESFÜGBAR BEI C3512

TIPOS DE RESPALDO
TYPES DE DOSSIER
TYPES OF BACKREST
OPTIONEN RÜCKENTEILE

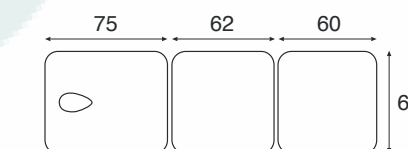
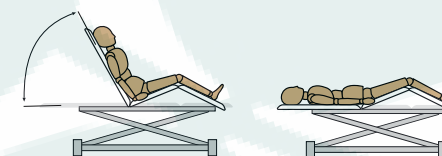

Standard: 62 x 198 cm. (M46)
Opcional: 70 x 198 cm. (M66)



C7726



41 Blanc	42 Gris	43 Noir	44 Jonquille	45 Banane	46 Ocre	47 Rose	48 Clémentine	49 Coquelicot	50 Framboise	51 Iris	NEW 30 Cherry	
52 Lilas	53 Roi	54 Bleuets	55 Ciel	56 Sanitaire	57 Java	58 Kiwi	59 Gazon	60 Celadon	61 Crème	62 Marron	31 Smoke	32 Anthracite

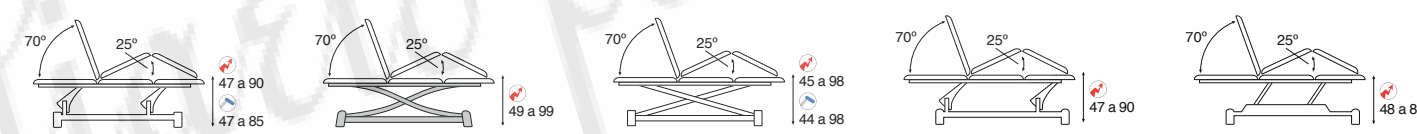

C5526 / C5726

C7926

C7526 / C7726

C3525

C3512



ecopostural
mobiliario para la salud.

2 CUERPOS

2 PLANS · 2 SECTION · 2 SEGMENTE



PRODUCTO FABRICADO EN ESPAÑA
PRODUIT FABRIQUÉ EN ESPAGNE
PRODUCT MADE IN SPAIN
PRODUKT HERGESTELLT IN SPANIEN



www.ecopostural.com
PARA MÁS DETALLES Y ÚLTIMAS NOVEDADES
POUR INFORMATION DÉTAILLÉE & NOUVEAUTÉS
FOR DETAILED INFORMATION & NEW PRODUCTS
FÜR WEITERE DETAILS UND NEUHEITEN



C6102W

135 Kg



C6202

135 Kg



C5902

250 Kg



C7902

200 Kg



C5502

175 Kg



C7502

175 Kg

TIPOS DE RESPALDO

TYPES DE DOSSIER
TYPES OF BACKREST
OPTIONEN RÜCKENTEILE

STANDARD BAJO PEDIDO / SUR DEMANDE / ON ORDER / AUFANFRAGE



T33



T35

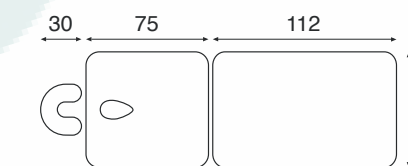
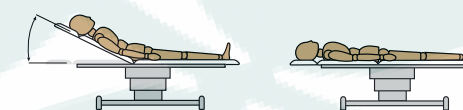

7cm



Standard: 70 x 188 cm. (M64)
Opcional: 80 x 188 cm. (M74)



C6102W

135 Kg

41 Blanc	42 Gris	43 Noir	44 Jonquille	45 Banane	46 Ocre	47 Rose	48 Clémentine	49 Coquelicot	50 Framboise	51 Iris	NEW 30 Cherry	
52 Lilas	53 Roi	54 Bleuets	55 Ciel	56 Sanitaire	57 Java	58 Kivi	59 Gazon	60 Celadon	61 Crème	62 Marron	31 Smoke	32 Anthracite

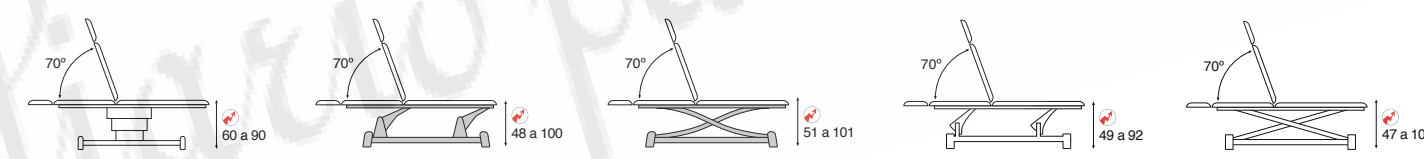

C6102W / C6202

C5902

C7902

C5502

C7502



C5984



C5983



C5584

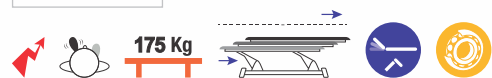

C5583

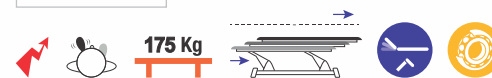

C5784

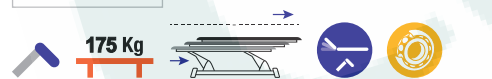

C5783

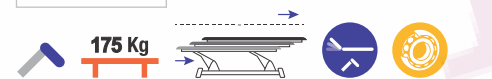

TIPOS DE RESPALDO
TYPES DE DOSSIER
TYPES OF BACKREST
OPTIONEN RÜCKENTEILE

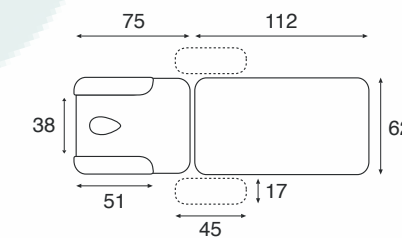

Standard: 62 x 188 cm. (M44)
Opcional: 70 x 188 cm. (M64)



C5983



41 Blanc	42 Gris	43 Noir	44 Jonquille	45 Banane	46 Ocre	47 Rose	48 Clémentine	49 Coquelicot	50 Framboise	51 Iris	NEW 30 Cherry	
52 Lilas	53 Roi	54 Bleuet	55 Ciel	56 Sanitaire	57 Java	58 Kiwi	59 Gazon	60 Celadon	61 Crème	62 Marron	31 Smoke	32 Anthracite



C5983 / C5984

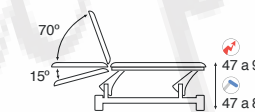

C5583 / C5783
C5584 / C5784



C7934



C7933



C7534



C7533



C7734



C7733



TIPOS DE RESPALDO

TYPES DE DOSSIER
TYPES OF BACKREST
OPTIONEN RÜCKENTEILE

STANDARD



T20

BAJO PEDIDO / SUR DEMANDE / ON ORDER / AUF ANFRAGE



T21

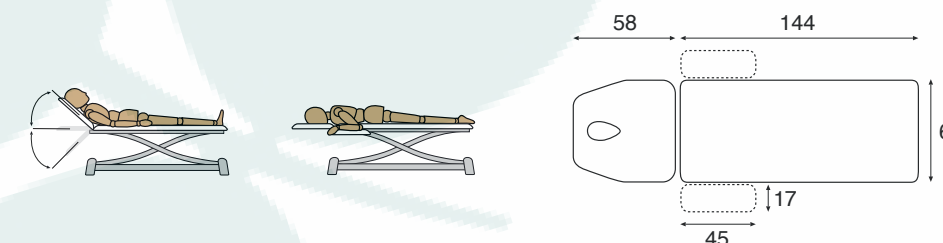

Standard: 62 x 207 cm. (M48)



C7934



41 Blanc	42 Gris	43 Noir	44 Jonquille	45 Banane	46 Ocre	47 Rose	48 Clémentine	49 Coquelicot	50 Framboise	51 Iris	NEW 30 Cherry	
52 Lilas	53 Roi	54 Bleuets	55 Ciel	56 Sanitaire	57 Java	58 Kiwi	59 Gazon	60 Celadon	61 Crème	62 Marron	31 Smoke	32 Anthracite

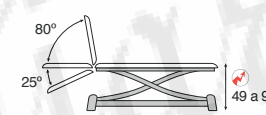

C7933 / C7934

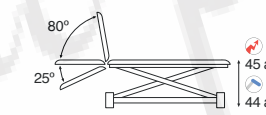

C7533 / C7733
C7534 / C7734



C5934



C5933



C5534

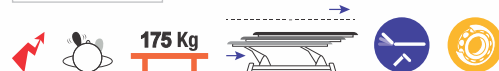

C5533

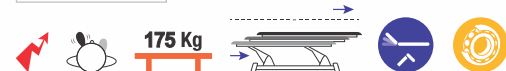

C5734



C5733

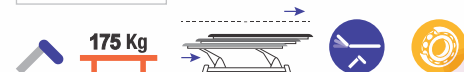

TIPOS DE RESPALDO

TYPES DE DOSSIER
TYPES OF BACKREST
OPTIONEN RÜCKENTEILE

STANDARD BAJO PEDIDO / SUR DEMANDE / ON ORDER / AUF ANFRAGE



T 13 T 14 T 15

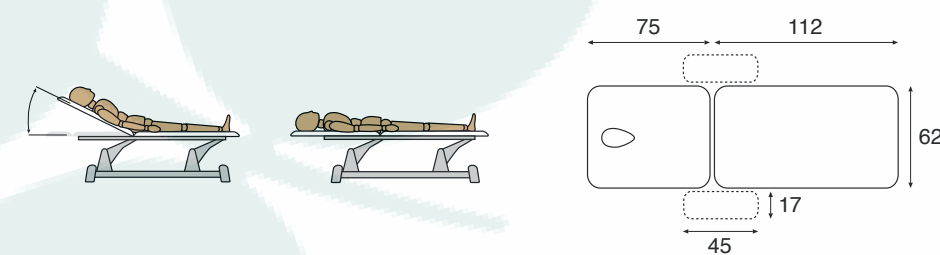

Standard: 62 x 188 cm. (M44)
Opcional: 70 x 188 cm. (M64)



C5934



41 Blanc	42 Gris	43 Noir	44 Jonquille	45 Banane	46 Ocre	47 Rose	48 Clémentine	49 Coquelicot	50 Framboise	51 Iris	NEW 30 Cherry	
52 Lilas	53 Roi	54 Bleuets	55 Ciel	56 Sanitaire	57 Java	58 Kiwi	59 Gazon	60 Celadon	61 Crème	62 Marron	31 Smoke	32 Anthracite

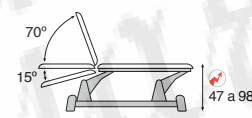

C5934 / C5933

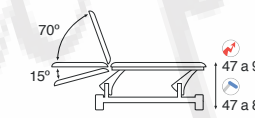

C5534 / C5533
C5734 / C5733

2 CUERPOS
2 PLANS
2 SECTION
2 SEGMENTE

2 CUERPOS
2 PLANS
2 SECTION
2 SEGMENTE



C5951



C7951



C5551

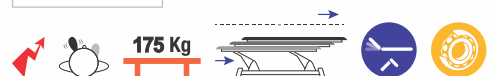

C7551



C5751

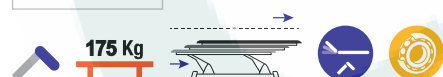

C7751



TIPOS DE RESPALDO

TYPES DE DOSSIER
TYPES OF BACKREST
OPTIONEN RÜCKENTEILE



STANDARD BAJO PEDIDO / SUR DEMANDE / ON ORDER / AUF ANFRAGE



T13



T14



T15

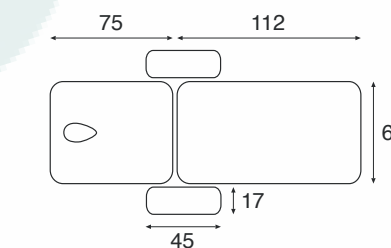

Standard: 62 x 188 cm. (M44)
Opcional: 70 x 188 cm. (M64)



C5951H



41 Blanc	42 Gris	43 Noir	44 Jonquille	45 Banane	46 Ocre	47 Rose	48 Clementine	49 Coquelicot	50 Framboise	51 Iris	NEW 30 Cherry	
52 Lilas	53 Roi	54 Bleuets	55 Ciel	56 Sanitaire	57 Java	58 Kiwi	59 Gazon	60 Celadon	61 Crème	62 Marron	31 Smoke	32 Anthracite

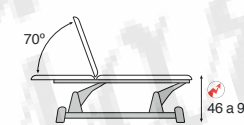

C5951H / C5951



C7951

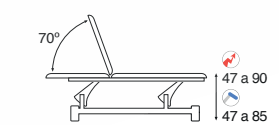

C5551 / C5751

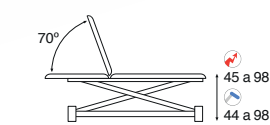

C7551 / C7751



C5952H



C7952



C5952



C7552



C5552



C7752



TIPOS DE RESPALDO

TYPES DE DOSSIER
TYPES OF BACKREST
OPTIONEN RÜCKENTEILE

STANDARD BAJO PEDIDO / SUR DEMANDE / ON ORDER / AUF ANFRAGE



T 13



T 14



T 15

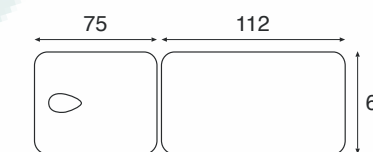
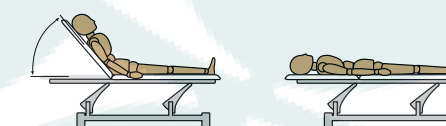

Standard: 62 x 188 cm. (M44)
Opcional: 70 x 188 cm. (M64)



C5752

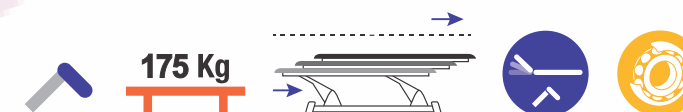

41 Blanc	42 Gris	43 Noir	44 Jonquille	45 Banane	46 Ocre	47 Rose	48 Clementine	49 Coquelicot	50 Framboise	51 Iris	NEW 30 Cherry	
52 Lilas	53 Roi	54 Bleuets	55 Ciel	56 Sanitaire	57 Java	58 Kiwi	59 Gazon	60 Celadon	61 Crème	62 Marron	31 Smoke	32 Anthracite

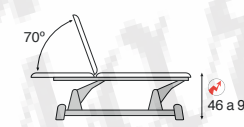

C5952H / C5952



C7952

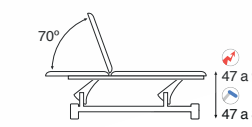

C5552 / C5752

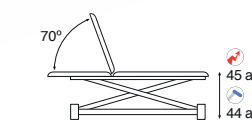

C7552 / C7752



C3553

135 Kg



C3753

135 Kg



C3523

150 Kg



C3723

150 Kg



C3513

135 Kg



C3500

135 Kg

Sin ruedas.
Sans roulettes.
Without wheels.
Ohne Räder

TIPOS DE RESPALDO
TYPES DE DOSSIER
TYPES OF BACKREST
OPTIONEN RÜCKENTEILE

STANDARD



T 13

BAJO PEDIDO / SUR DEMANDE / ON ORDER / AUF ANFRAGE



T 14



T 15

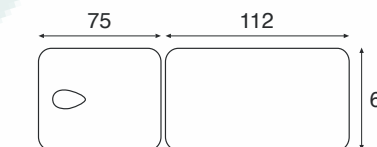
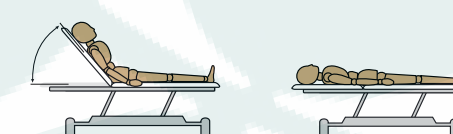

Standard: 62 x 188 cm. (M44)
Opcional: 70 x 188 cm. (M64)



C3513

135 Kg

41 Blanc	42 Gris	43 Noir	44 Jonquille	45 Banane	46 Ocre	47 Rose	48 Clémentine	49 Coquelicot	50 Framboise	51 Iris	NEW 30 Cherry	
52 Lilas	53 Roi	54 Bleuets	55 Ciel	56 Sanitaire	57 Java	58 Kiwi	59 Gazon	60 Celadon	61 Crème	62 Marron	31 Smoke	32 Anthracite

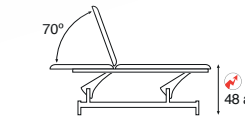
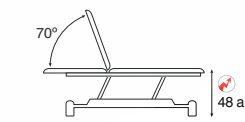
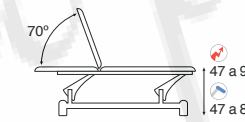
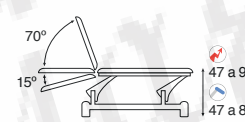

C3553 / C3753

C3523 / C3723

C3513

C3500

T14 NO DISPONIBLE EN LA C3513
T14 NON DISPONIBLE SUR CE MODÈLE C3513
T14 NOT AVAILABLE IN THIS MODEL C3513
T14 NICHT VESFÜGBAR BEI C3513





ecopostural
mobiliario para la salud.

FIJAS
FIXES · STATIONARY · STATIONÄRE



PRODUCTO FABRICADO EN ESPAÑA
PRODUIT FABRIQUÉ EN ESPAGNE
PRODUCT MADE IN SPAIN
PRODUKT HERGESTELLT IN SPANIEN



www.ecopostural.com
PARA MÁS DETALLES Y ÚLTIMAS NOVEDADES
POUR INFORMATION DÉTAILLÉE & NOUVEAUTÉS
FOR DETAILED INFORMATION & NEW PRODUCTS
FÜR WEITERE DETAILS UND NEUHEITEN



C3249W



C3269



C3259W



C3279



TIPOS DE RESPALDO
TYPES DE DOSSIER
TYPES OF BACKREST
OPTIONEN RÜCKENTEILE

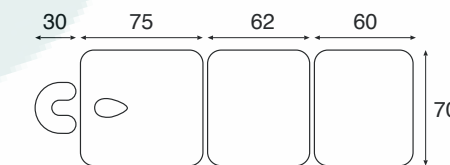
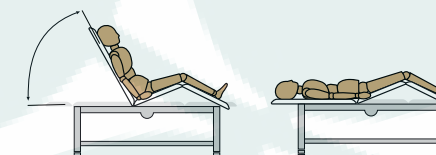

Standard: 70 x 198 cm. (M66)
Opcional: 80 x 198 cm. (M76)



C3249W



- | | | | | | | | | | | | | |
|----------|---------|------------|--------------|--------------|---------|---------|---------------|---------------|--------------|-----------|----------|---------------|
| 41 Blanc | 42 Gris | 43 Noir | 44 Jonquille | 45 Banane | 46 Ocre | 47 Rose | 48 Clémentine | 49 Coquelicot | 50 Framboise | 51 Iris | NEW | 30 Cherry |
| 52 Lilas | 53 Roi | 54 Bleuets | 55 Ciel | 56 Sanitaire | 57 Java | 58 Kiwi | 59 Gazon | 60 Celadon | 61 Crème | 62 Marron | 31 Smoke | 32 Anthracite |

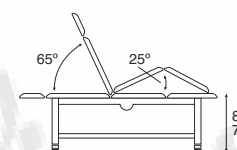

C3249W / C3269

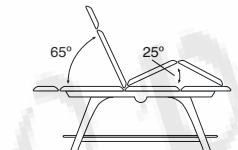

C3259W / C3279

ecopostural
mobilización para la salud



C3239W



C3229



C4519



C3123



TIPOS DE RESPALDO
TYPES DE DOSSIER
TYPES OF BACKREST
OPTIONEN RÜCKENTEILE

STANDARD BAJO PEDIDO / SUR DEMANDE / ON ORDER / AUF ANFRAGE



T 13



T 15

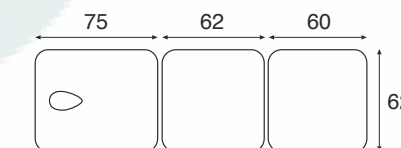
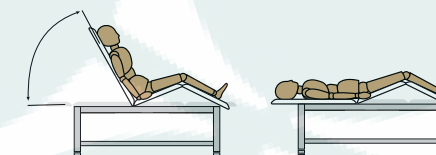

Standard: 62 x 198 cm. (M46)
Opcional: 70 x 198 cm. (M66)



C3239W



41	Bianc	42	Gris	43	Noir	44	Jonquille	45	Banane	46	Ocre	47	Rose	48	Clémentine	49	Coquelicot	50	Framboise	51	Iris	NEW	30	Cherry	
52	Lilas	53	Roi	54	Bleuet	55	Ciel	56	Sanitaire	57	Java	58	Kiwi	59	Gazon	60	Celadon	61	Crème	62	Marron	31	Smoke	32	Anthracite

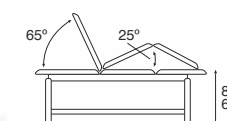

C3239W / C3229

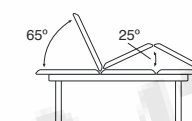

C3123

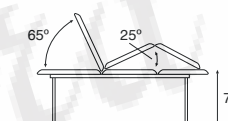

C4519



C3240W



C3260

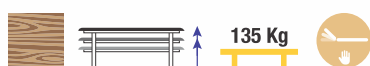

C3250W



C3270



TIPOS DE RESPALDO
TYPES DE DOSSIER
TYPES OF BACKREST
OPTIONEN RÜCKENTEILE

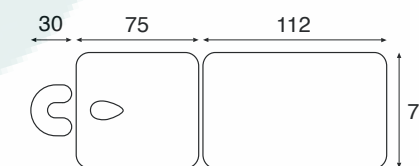
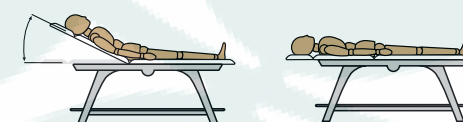

Standard: 70 x 188 cm. (M64)
Opcional: 80 x 188 cm. (M74)



C3270

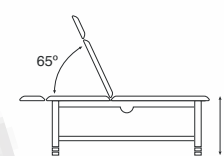

C3240W / C3260

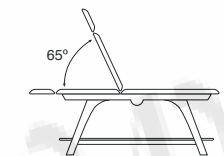

C3250W / C3270

41 Blanc	42 Gris	43 Noir	44 Jonquille	45 Banane	46 Ocre	47 Rose	48 Clémentine	49 Coquelicot	50 Framboise	51 Iris	NEW 30 Cherry
52 Lilas	53 Roi	54 Bleuets	55 Ciel	56 Sanitaire	57 Java	58 Kari	59 Gazon	60 Celadon	61 Crème	62 Marron	31 Smoke 32 Anthracite

ecopostural
mobilización para la salud



C3230W

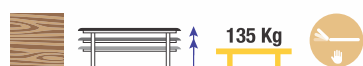

C3220



C3122



C4592



C4520



- | | | | | | | | | | | | | |
|----------|---------|------------|--------------|--------------|---------|---------|---------------|---------------|--------------|-----------|----------------------|---------------|
| 41 Blanc | 42 Gris | 43 Noir | 44 Jonquille | 45 Banane | 46 Ocre | 47 Rose | 48 Clémentine | 49 Coquelicot | 50 Framboise | 51 Iris | NEW 30 Cherry | |
| 52 Lilas | 53 Roi | 54 Bleuets | 55 Ciel | 56 Sanitaire | 57 Java | 58 Kiwi | 59 Gazon | 60 Celadon | 61 Crème | 62 Marron | 31 Smoke | 32 Anthracite |



C3220 / C3230W



C3122

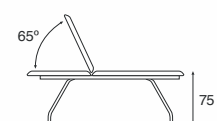

C4592



C4520

TIPOS DE RESPALDO
TYPES DE DOSSIER
TYPES OF BACKREST
OPTIONEN RÜCKENTEILE



T13



T15

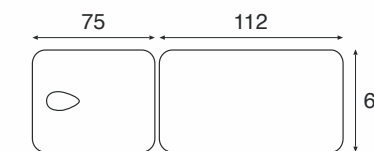
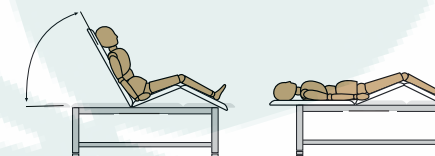

Standard: 62 x 188 cm. (M44)
Opcional: 70 x 188 cm. (M64)



C3220

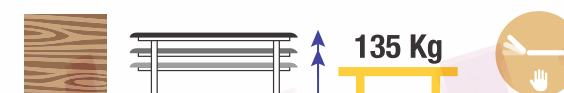

STANDARD BAJO PEDIDO / SUR DEMANDE / ON ORDER / AUF ANFRAGE



T07



T09

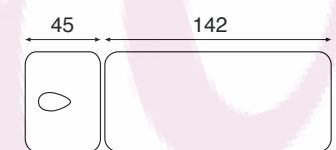

Standard: 62 x 188 cm. (M44)
Opcional: 70 x 188 cm. (M64)

TIPOS DE RESPALDO
TYPES DE DOSSIER
TYPES OF BACKREST
OPTIONEN RÜCKENTEILE



C3125

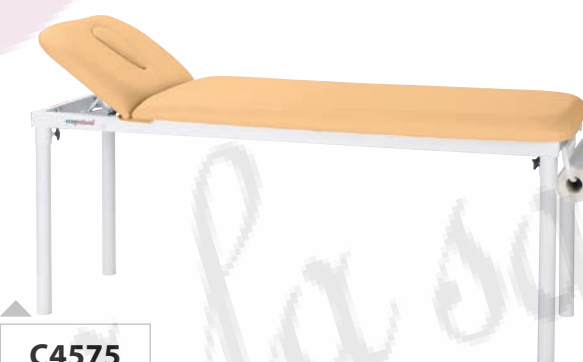

C4575



- | | | | | | | | | | | | | |
|----------|---------|------------|--------------|--------------|---------|---------|---------------|---------------|--------------|-----------|----------------------|---------------|
| 41 Blanc | 42 Gris | 43 Noir | 44 Jonquille | 45 Banane | 46 Ocre | 47 Rose | 48 Clémentine | 49 Coquelicot | 50 Framboise | 51 Iris | NEW 30 Cherry | |
| 52 Lilas | 53 Roi | 54 Bleuets | 55 Ciel | 56 Sanitaire | 57 Java | 58 Kiwi | 59 Gazon | 60 Celadon | 61 Crème | 62 Marron | 31 Smoke | 32 Anthracite |

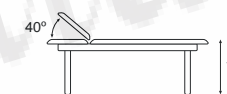

C3125

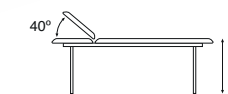

C4575



PACK02



* Standard: 62 x 188 cm. (M44)
Opcional: 70 x 188 cm. (M64)



PACK01

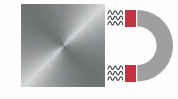

* Standard: 62 x 188 cm. (M44)
Opcional: 70 x 188 cm. (M64)



PACK03



* Standard: 62 x 188 cm. (M44)
Opcional: 70 x 188 cm. (M64)



PACK04



* Standard: 62 x 200 cm. (M47)
Opcional: 70 x 200 cm. (M67)

OPCIÓN ESTRIBOS
OPTION ÉTRIERS · STIRRUPS OPTIONALLY AVAILABLE
OPTION FERSENSTÜTZEN

- | | | | | | | | | | | | |
|----------|---------|------------|--------------|--------------|---------|---------|---------------|---------------|--------------|-----------|------------------------|
| 41 Blanc | 42 Gris | 43 Noir | 44 Jonquille | 45 Banane | 46 Ocre | 47 Rose | 48 Clémentine | 49 Coquelicot | 50 Framboise | 51 Iris | NEW 30 Cherry |
| 52 Lilas | 53 Roi | 54 Bleuets | 55 Gel | 56 Sanitaire | 57 Java | 58 Kiwi | 59 Gazon | 60 Celadon | 61 Crème | 62 Marron | 31 Smoke 32 Anthracite |

- | | | | | | | | | | | | |
|----------|---------|------------|--------------|--------------|---------|---------|---------------|---------------|--------------|-----------|------------------------|
| 41 Blanc | 42 Gris | 43 Noir | 44 Jonquille | 45 Banane | 46 Ocre | 47 Rose | 48 Clémentine | 49 Coquelicot | 50 Framboise | 51 Iris | NEW 30 Cherry |
| 52 Lilas | 53 Roi | 54 Bleuets | 55 Gel | 56 Sanitaire | 57 Java | 58 Kiwi | 59 Gazon | 60 Celadon | 61 Crème | 62 Marron | 31 Smoke 32 Anthracite |



ecopostural
mobiliario para la salud.

PLEGABLES

PLIANTES · PORTABLE · KOFFERMASSEGEBÄNKE



PRODUCTO FABRICADO EN ESPAÑA
PRODUIT FABRIQUÉ EN ESPAGNE
PRODUCT MADE IN SPAIN
PRODUKT HERGESTELLT IN SPANIEN



www.ecopostural.com
PARA MÁS DETALLES Y ÚLTIMAS NOVEDADES
POUR INFORMATION DÉTAILLÉE & NOUVEAUTÉS
FOR DETAILED INFORMATION & NEW PRODUCTS
FÜR WEITERE DETAILS UND NEUHEITEN



STANDARD



Standard: 70 x 186 cm. (M63)

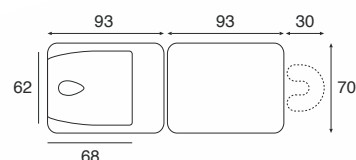

T 22

STANDARD



Standard: 70 x 182 cm. (M61)

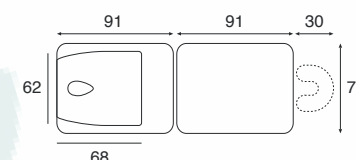

T 22



C3616

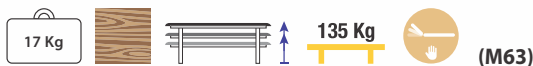

C3614

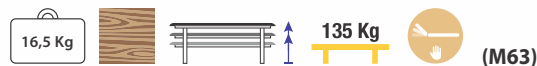

C3216



C3214

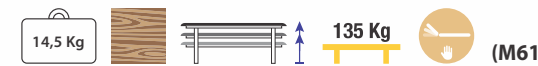

C3816

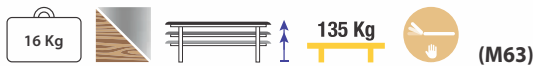

C3814

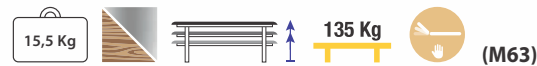

C3316

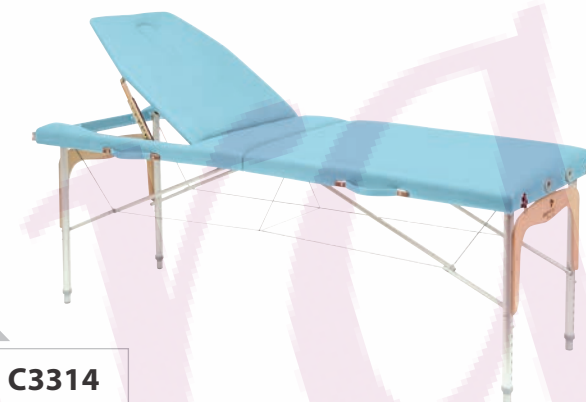
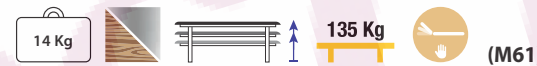

C3314

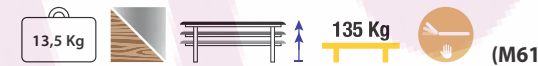

C3416

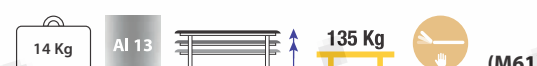

C3414



- | | | | | | | | | | | | | |
|----------|---------|-----------|--------------|--------------|---------|---------|---------------|---------------|--------------|-----------|----------------------|---------------|
| 41 Blanc | 42 Gris | 43 Noir | 44 Jonquille | 45 Banane | 46 Ocre | 47 Rose | 48 Clémentine | 49 Coquelicot | 50 Framboise | 51 Iris | NEW 30 Cherry | |
| 52 Lilas | 53 Roi | 54 Bleuet | 55 Ciel | 56 Sanitaire | 57 Java | 58 Kiwi | 59 Gazon | 60 Celadon | 61 Crème | 62 Marron | 31 Smoke | 32 Anthracite |

- | | | | | | | | | | | | | |
|----------|---------|-----------|--------------|--------------|---------|---------|---------------|---------------|--------------|-----------|----------------------|---------------|
| 41 Blanc | 42 Gris | 43 Noir | 44 Jonquille | 45 Banane | 46 Ocre | 47 Rose | 48 Clémentine | 49 Coquelicot | 50 Framboise | 51 Iris | NEW 30 Cherry | |
| 52 Lilas | 53 Roi | 54 Bleuet | 55 Ciel | 56 Sanitaire | 57 Java | 58 Kiwi | 59 Gazon | 60 Celadon | 61 Crème | 62 Marron | 31 Smoke | 32 Anthracite |

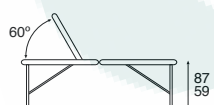

C3616 / C3614

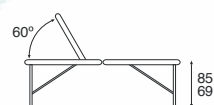

C3816 / C3814

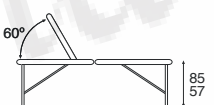

C3216 / C3214

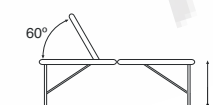

C3316 / C3314
C3416 / C3414

PLEGABLES
PLIANTES
PORTABLE
KOFFERMASSAGEBÄNKE

PLEGABLES
PLIANTES
PORTABLE
KOFFERMASSAGEBÄNKE

STANDARD



Standard: 70 x 186 cm. (M63)

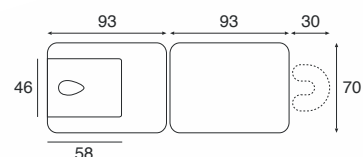

STANDARD



Standard: 70 x 182 cm. (M61)
Opcional: 62 x 182 cm. (M41)
Opcional: 70 x 192 cm. (M65)

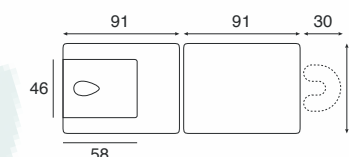

C3610



(M63)



C3609

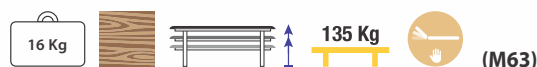

(M63)



C3210



(M61) (M65)



C3209



(M61) (M65)



C3810

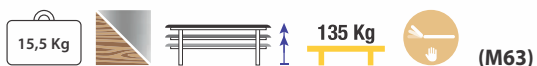

(M63)



C3809

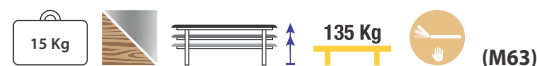

(M63)

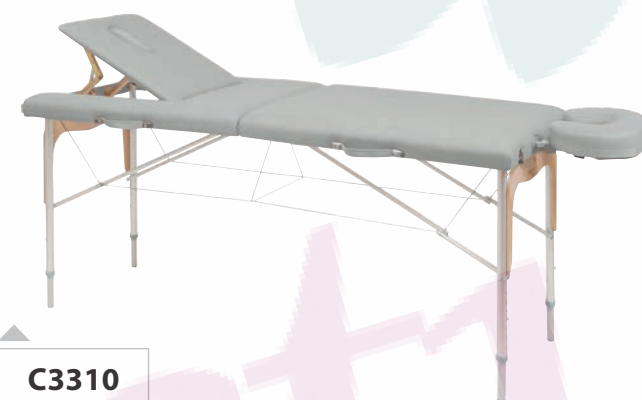

C3310



(M61) (M41) (M65)

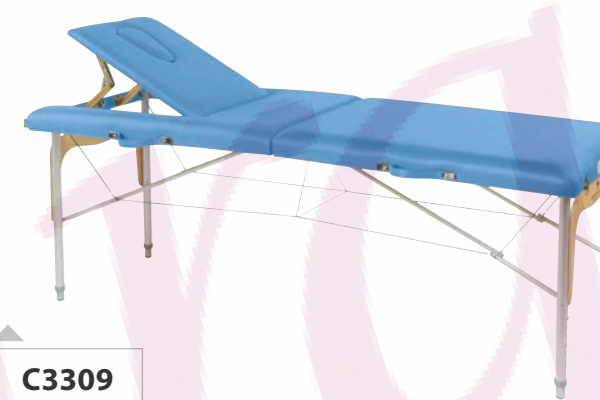

C3309



(M61) (M41) (M65)

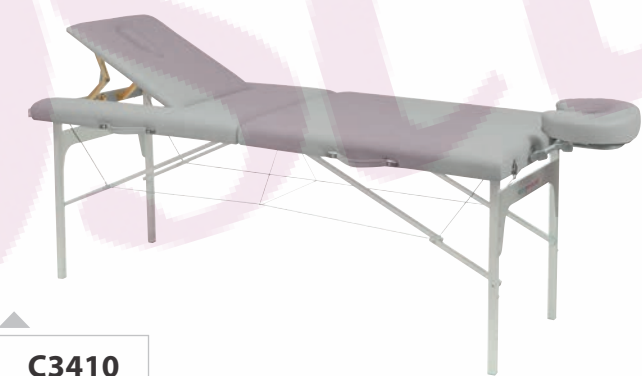

C3410



(M61) (M41) (M65)



C3409



(M61) (M41) (M65)

- | | | | | | | | | | | | | |
|----------|---------|------------|--------------|--------------|---------|---------|---------------|---------------|--------------|-----------|----------------------|---------------|
| 41 Blanc | 42 Gris | 43 Noir | 44 Jonquille | 45 Banane | 46 Ocre | 47 Rose | 48 Clémentine | 49 Coquelicot | 50 Framboise | 51 Iris | NEW 30 Cherry | |
| 52 Lilas | 53 Roi | 54 Bleuets | 55 Ciel | 56 Sanitaire | 57 Java | 58 Kiwi | 59 Gazon | 60 Celadon | 61 Crème | 62 Marron | 31 Smoke | 32 Anthracite |

- | | | | | | | | | | | | | |
|----------|---------|------------|--------------|--------------|---------|---------|---------------|---------------|--------------|-----------|----------------------|---------------|
| 41 Blanc | 42 Gris | 43 Noir | 44 Jonquille | 45 Banane | 46 Ocre | 47 Rose | 48 Clémentine | 49 Coquelicot | 50 Framboise | 51 Iris | NEW 30 Cherry | |
| 52 Lilas | 53 Roi | 54 Bleuets | 55 Ciel | 56 Sanitaire | 57 Java | 58 Kiwi | 59 Gazon | 60 Celadon | 61 Crème | 62 Marron | 31 Smoke | 32 Anthracite |

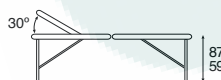

C3610 / C3609

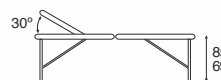

C3810 / C3809

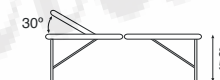

C3210 / C3209

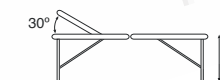

C3310 / C3309
C3410 / C3409



STANDARD

BAJO PEDIDO / SUR DEMANDE / ON ORDER / AUF ANFRAGE



T 94



T 95

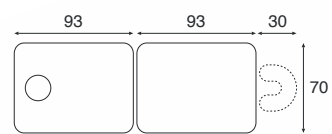

Standard: 70 x 186 cm. (M63)



STANDARD

BAJO PEDIDO / SUR DEMANDE / ON ORDER / AUF ANFRAGE



T 93



T 95



Standard: 70 x 182 cm. (M61)
Opcional: 62 x 182 cm. (M41)
Opcional: 70 x 192 cm. (M65)



C3608

15,5 Kg 135 Kg (M63)



C3611

15 Kg 135 Kg (M63)

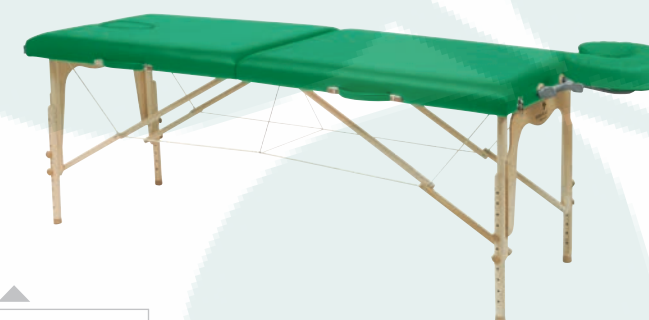

C3208

13,5 Kg 135 Kg (M61) (M65)



C3211

13 Kg 135 Kg (M61) (M65)



C3808

14,5 Kg 135 Kg (M63)



C3811

14 Kg 135 Kg (M63)



C3308

12,5 Kg 135 Kg (M61) (M41) (M65)

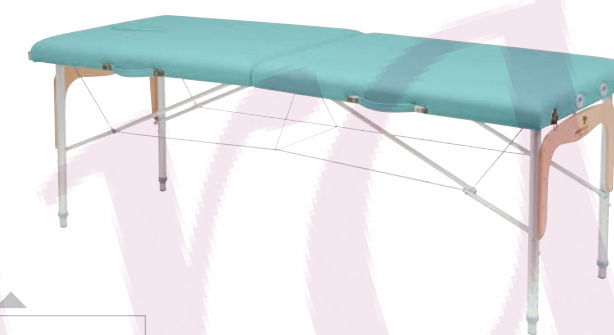

C3311

12 Kg 135 Kg (M61) (M41) (M65)



C3408

12,5 Kg Al 13 135 Kg (M61) (M41) (M65)



C3411

12 Kg Al 13 135 Kg (M61) (M41) (M65)

- | | | | | | | | | | | | | |
|----------|---------|------------|--------------|--------------|---------|---------|---------------|---------------|--------------|-----------|---------------|---------------|
| 41 Blanc | 42 Gris | 43 Noir | 44 Jonquille | 45 Banane | 46 Ocre | 47 Rose | 48 Clémentine | 49 Coquelicot | 50 Framboise | 51 Iris | NEW 30 Cherry | |
| 52 Lilas | 53 Roi | 54 Bleuets | 55 Ciel | 56 Sanitaire | 57 Java | 58 Kiwi | 59 Gazon | 60 Celadon | 61 Crème | 62 Marron | 31 Smoke | 32 Anthracite |

- | | | | | | | | | | | | | |
|----------|---------|------------|--------------|--------------|---------|---------|---------------|---------------|--------------|-----------|---------------|---------------|
| 41 Blanc | 42 Gris | 43 Noir | 44 Jonquille | 45 Banane | 46 Ocre | 47 Rose | 48 Clémentine | 49 Coquelicot | 50 Framboise | 51 Iris | NEW 30 Cherry | |
| 52 Lilas | 53 Roi | 54 Bleuets | 55 Ciel | 56 Sanitaire | 57 Java | 58 Kiwi | 59 Gazon | 60 Celadon | 61 Crème | 62 Marron | 31 Smoke | 32 Anthracite |



C3608 / C3611



C3808 / C3811



C3208 / C3211



C3308 / C3311
C3408 / C3411



Standard: 70 x 182 cm. (M61)

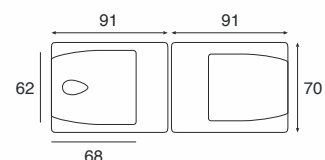

C3213



C3413



Standard: 70 x 182 cm. (M61)
Opcional: 70 x 192 cm. (M65)



Standard: 50 x 182 cm. (M11)

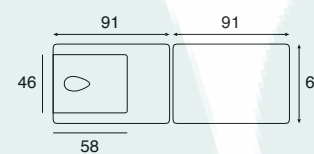
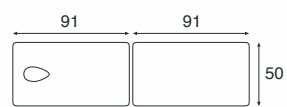

Standard: 62 x 182 cm. (M41)
Opcional: 70 x 182 cm. (M61)
Opcional: 70 x 192 cm. (M65)

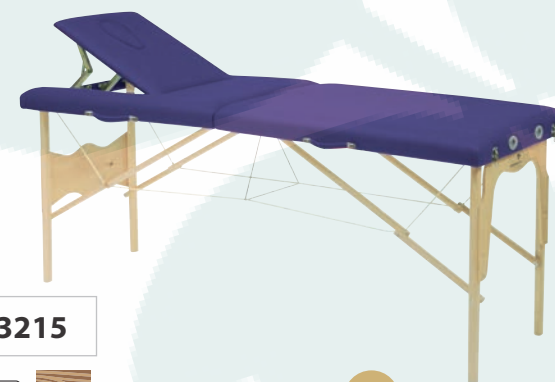

C3215



Standard: 62 x 182 cm. (M41)
Opcional: 70 x 182 cm. (M61)
Opcional: 70 x 192 cm. (M65)



C3212



C3415

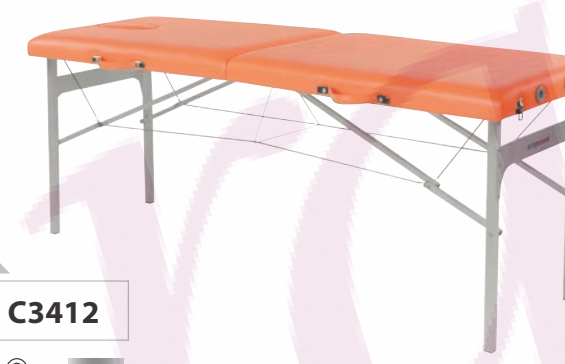

C3412



41 Blanc	42 Gris	43 Noir	44 Jonquille	45 Banane	46 Ocre	47 Rose	48 Clémentine	49 Coquelicot	50 Framboise	51 Iris	NEW 30 Cherry	
52 Lilas	53 Roi	54 Bleuets	55 Ciel	56 Sanitaire	57 Java	58 Kiwi	59 Gazon	60 Celadon	61 Crème	62 Marron	31 Smoke	32 Anthracite

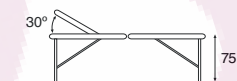

C3215 /C3415



C3212 /C3412

ACCESORIOS PARA CAMILLAS PLEGABLES
ACCESSOIRES POUR TABLES PLIANTES · ATTACHMENTS FOR PORTABLE TABLES
ZUBEHÖR FÜR KOFFERMASSAGEBANK



A4450F/G 70x182/192 cm.



A4451F/G 70x182/192 cm.



A4473



A4435

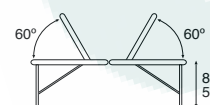

C3213

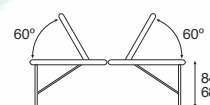

C3413



C3111



C3100

ecopostural
mueblario para la salud.

INVERSOR / S.TERAPIAS

T. INVERSION / C. THÉRAPIES · INVERSION T. / THERAPY C.
INVERSIONSBANK / THERAPIESTUHL



PRODUCTO FABRICADO EN ESPAÑA
PRODUIT FABRIQUÉ EN ESPAGNE
PRODUCT MADE IN SPAIN
PRODUKT HERGESTELLT IN SPANIEN



www.ecopostural.com
PARA MÁS DETALLES Y ÚLTIMAS NOVEDADES
POUR INFORMATION DÉTAILLÉE & NOUVEAUTÉS
FOR DETAILED INFORMATION & NEW PRODUCTS
FÜR WEITERE DETAILS UND NEUHEITEN

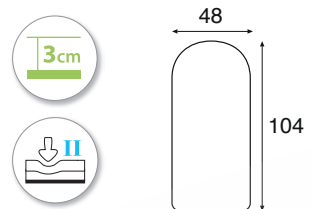

T1500

135 Kg

- | | | | | | | | | | | | |
|----------|---------|------------|--------------|--------------|---------|---------|---------------|---------------|--------------|-----------|------------------------|
| 41 Blanc | 42 Gris | 43 Noir | 44 Jonquille | 45 Banane | 46 Ocre | 47 Rose | 48 Clémentine | 49 Coquelicot | 50 Framboise | 51 Iris | NEW 30 Cherry |
| 52 Lilas | 53 Roi | 54 Bleuets | 55 Ciel | 56 Sanitaire | 57 Java | 58 Kiwi | 59 Gazon | 60 Celadon | 61 Crème | 62 Marron | 31 Smoke 32 Anthracite |

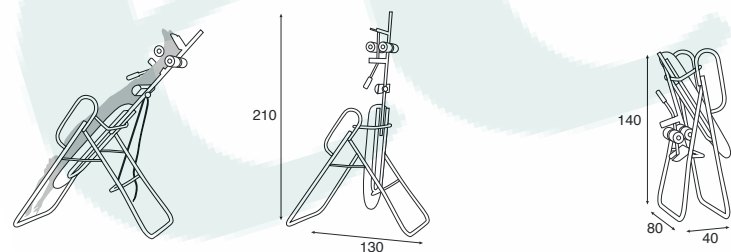

T1500

T1500

PLEGADO · REPLIÉ · FLAT FOLD · KLAPPBAR

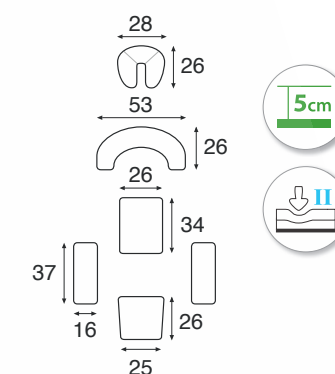

T2701

135 Kg

SOPORTE PARA MASAJE
 MODÈLE PLIANT · DESKTOP
 TISCHAUFSATZ



T4426

AI 13

- | | | | | | | | | | | | |
|----------|---------|------------|--------------|--------------|---------|---------|---------------|---------------|--------------|-----------|------------------------|
| 41 Blanc | 42 Gris | 43 Noir | 44 Jonquille | 45 Banane | 46 Ocre | 47 Rose | 48 Clémentine | 49 Coquelicot | 50 Framboise | 51 Iris | NEW 30 Cherry |
| 52 Lilas | 53 Roi | 54 Bleuets | 55 Ciel | 56 Sanitaire | 57 Java | 58 Kiwi | 59 Gazon | 60 Celadon | 61 Crème | 62 Marron | 31 Smoke 32 Anthracite |

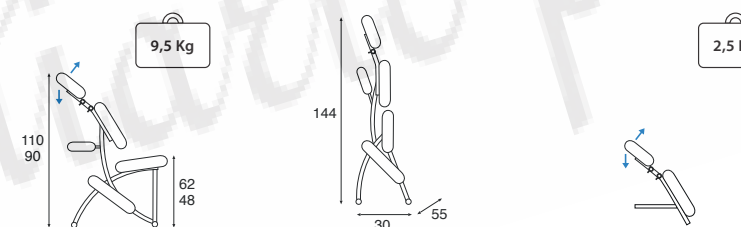

T2701

T2701

PLEGADO · REPLIÉ · FLAT FOLD · KLAPPBAR

T4426

ecopostural
mobiliario para la salud.

TABURETES
TABOURETS · STOOLS · HOCKER



PRODUCTO FABRICADO EN ESPAÑA
PRODUIT FABRIQUÉ EN ESPAGNE
PRODUCT MADE IN SPAIN
PRODUKT HERGESTELLT IN SPANIEN



www.ecopostural.com
PARA MÁS DETALLES Y ÚLTIMAS NOVEDADES
POUR INFORMATION DÉTAILLÉE & NOUVEAUTÉS
FOR DETAILED INFORMATION & NEW PRODUCTS
FÜR WEITERE DETAILS UND NEUHEITEN



S5674



S5634



S5664



S4671



S3631



S3661



S5673



S5633



S5663



S4671AP



S3631AP

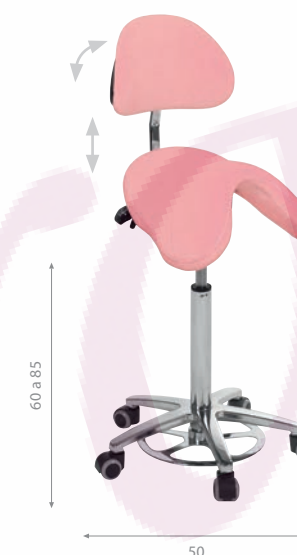

S3661AP



S5644



S5643



S5611GR

Brazo centrado en T
 Asiento de Ø36 cm
 Accoudoir en T
 Assise de Ø36 cm
 T-shaped arm support
 Ø36 cm seat
 T-Arm zentrierter
 Sitzfläche 36cm



S4639



S5609



S4609

41 Blanc	42 Gris	43 Noir	44 Jonquille	45 Banane	46 Ocre	47 Rose	48 Clémentine	49 Coquelicot	50 Framboise	51 Iris	NEW 30 Cherry	
52 Lilas	53 Roi	54 Bleuets	55 Ciel	56 Sanitaire	57 Java	58 Kiwi	59 Gazon	60 Celadon	61 Crème	62 Marron	31 Smoke	32 Anthracite



Se sirve desmontado.
Livré démonté
Packed disassembled
Wird zerlegt versendet



Opción de tacos en todos los taburetes y sillas.
Patins en option sur tous les tabourets et chaises
Grip feet optionally available in all stools and chairs
Alle Stühle / Hocker auch erhältlich mit Standbein



S2639



S4608

Solo negro. Espuma inyectada.
En noir uniquement. Mousse injectée.
Only available in black. Injected foam.
Nur schwarz. Schaumstoff eingespritzt



S2609



S5670AP



S5630AP



S5660AP



S2640



S3620



S2610



S4670



S3630



S3660



S2611PRV

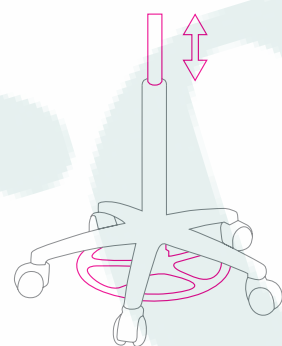

AP

ACCIONAMIENTO DE PIE
DÉCLENCHEMENT AU PIED
FOOT-OPERATED
FUSSPEDAL

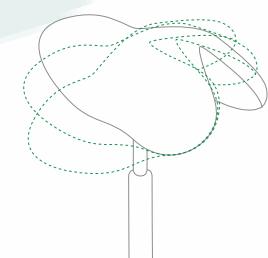

ASIENTO BASCULANTE
SIÈGE INCLINABLE
SEAT TILT
SITZFLÄCHE SCHWENKBAR



S4640



S5610



S4610

41 Blanc	42 Gris	43 Noir	44 Jonquille	45 Banane	46 Ocre	47 Rose	48 Clémentine	49 Coquelicot	50 Framboise	51 Iris	NEW	30 Cherry
52 Lilas	53 Roi	54 Bleuets	55 Ciel	56 Sanitaire	57 Java	58 Kiwi	59 Gazon	60 Celadon	61 Crème	62 Marron	31 Smoke	32 Anthracite



S2703



S2704



S2702



S2105

Plegable.
Pliant
Foldable
Klappbar



S2106

TIPOS DE ASIENTO Y MEDIDAS
SIÈGES ET DIMENSIONS · SEAT VARIANTS AND SIZES
SITZFLÄCHEN UND MASSE



S2603



S2604



S2602

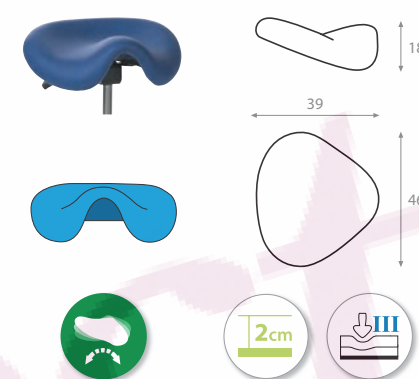

DERBY

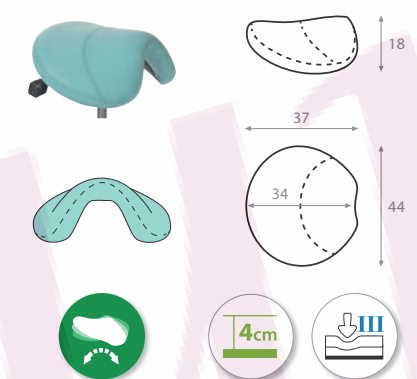

PONY

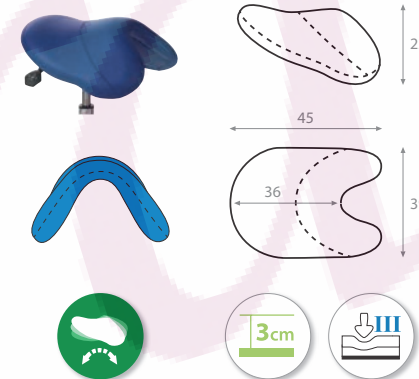

SILLA DE MONTAR



S2606



S2607

Opción de tacos en todos los taburetes y sillas.
Patins en option sur tous les tabourets et chaises
Grip feet optionally available in all stools and chairs
Alle Stühle / Hocker auch erhältlich mit Standbein

Se sirve desmontado.
Livré démonté
Packed disassembled
Wird zerlegt versendet

COLORES DISPONIBLES
TAPIZADO ARÁN (TELA)
COULEURS DISPONIBLES (TISSU ARAN)
AVAILABLE COLOURS (ARAN CLOTH)
FARBENAUSWAHL. POLSTER ARAN (STOFF)

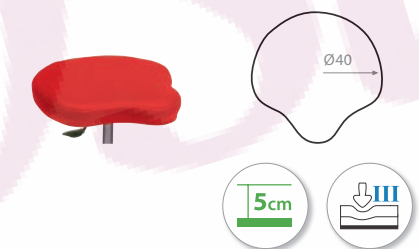

BICICLETA

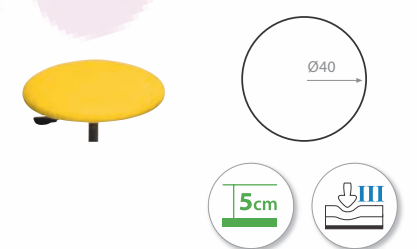

CIRCULAR



INTEGRAL

Espuma inyectada.
Mousse injectée.
Injected foam.
Schaumstoff eingespritzt



SILLA ERGONOMICA



SILLÓN ERGONOMICO

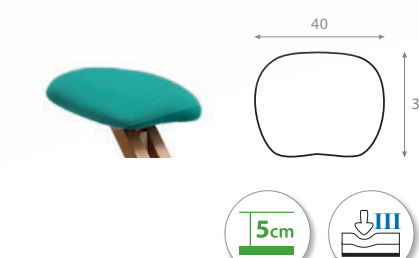

SILLA ERGONOMICA PLEGABLE

ecopostural
mobiliario para la salud.

ACCESORIOS

ACCESSOIRES · ACCESORIES · ZUBEHÖRE

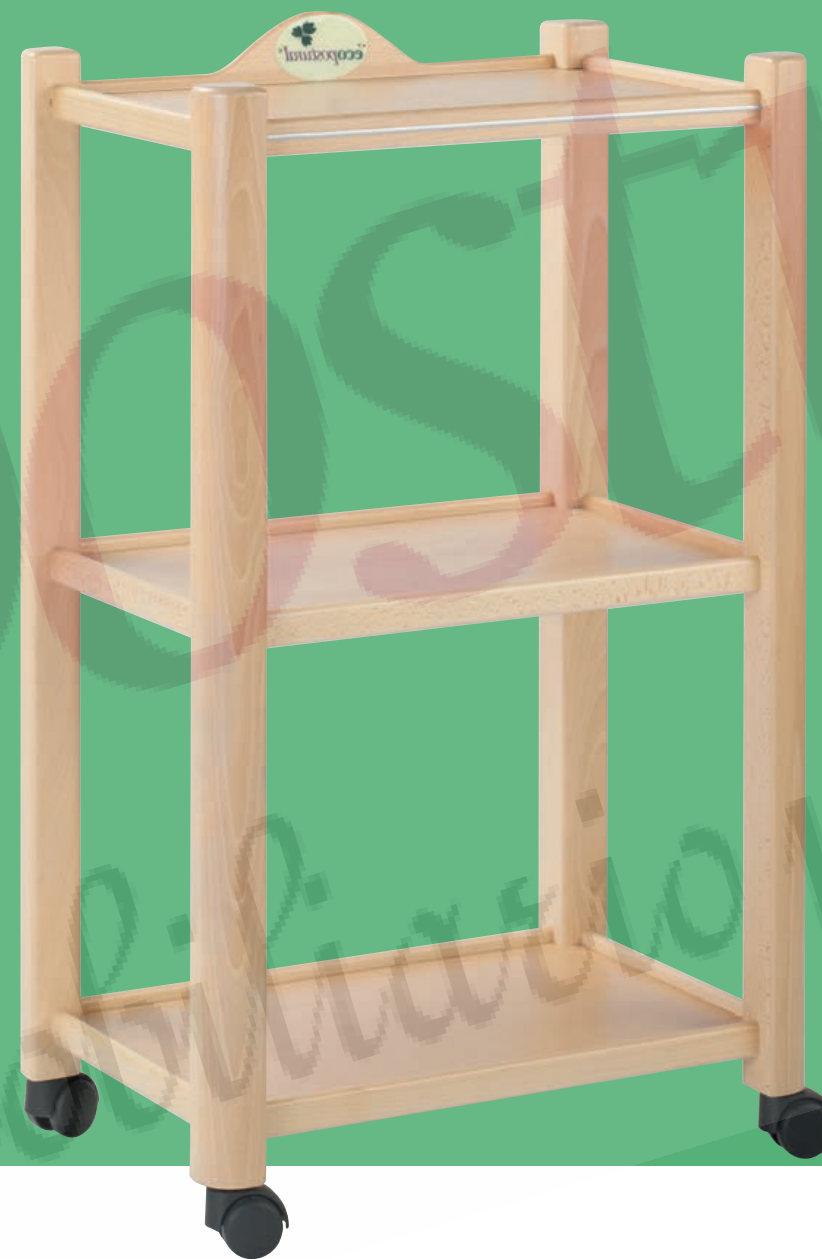

PRODUCTO FABRICADO EN ESPAÑA
PRODUIT FABRIQUÉ EN ESPAGNE
PRODUCT MADE IN SPAIN
PRODUKT HERGESTELLT IN SPANIEN



www.ecopostural.com
PARA MÁS DETALLES Y ÚLTIMAS NOVEDADES
POUR INFORMATION DÉTAILLÉE & NOUVEAUTÉS
FOR DETAILED INFORMATION & NEW PRODUCTS
FÜR WEITERE DETAILS UND NEUHEITEN

ACCESORIOS GENERALES
 ACCESSOIRES GÉNÉRAUX · GENERAL ACCESSORIES
 ZUBEHÖR ALLGEMEIN

Se sirve desmontado.
 Livré démonté
 Packed disassembled
 Wird zerlegt versendet



A4405



A4704



A4703

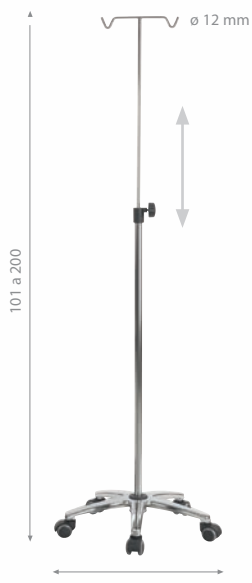

A4701

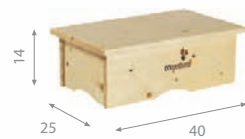

A4412

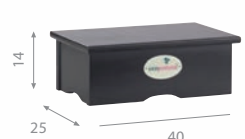

A4412W



A4442



A4443



A4444

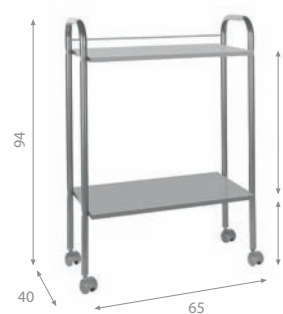

A4484

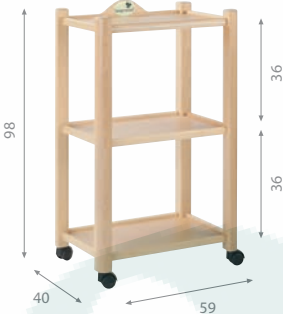

A4474



A4474W

ACCESORIOS PARA SILLA MULTIFUNCIÓN
 ACCESSOIRES POUR CHAISE MULTI-FONCTION
 ACCESSORIES FOR MULTI-FUNCTION CHAIR
 ZUBEHÖRE FÜR THERAPIESTUHL



A4455



A4433



A4458

ACCESORIOS DE PROTECCIÓN
 ACCESSOIRES DE PROTECTION
 PROTECTION ACCESSORIES
 SCHUTZZUBEHÖR

DE SERIE EN LOS SILLONES
 DE SÉRIE SUR LES FAUTEUILS
 INCLUDED AS STANDARD IN SPECIALTIES CHAIRS
 SERIEN MÄSSIG BEI BEHANDLUNGSTÜHLEN DABEI

ACCESORIOS PARA CAMILLAS ELÉCTRICAS / HIDRÁULICAS / FIJAS
 ACCESSOIRES POUR TABLES ÉLECTRIQUES / HYDRAULIQUES / FIXES · ATTACHMENTS FOR ELECTRIC / HYDRAULIC / STATIONARY TABLES
 ZUBEHÖR FÜR ELEKTRISCHE/HYDRAULISCHE/ STATIONÄRE LIEGEN



A4700

MANDO DE MANO CON SOPORTE MAGNÉTICO PARA CAMILLAS CON MOTOR. CONSULTAR MODELOS.
 Commande manuelle sur support magnétique pour tables avec moteur. Voir modèles.
 Handset with magnetic support for tables equipped with motor. Check models.
 Magnetischer Handschalter für elektrische Liegen. Modelle konsultieren.

R10MH-MM



A4705

MANDO DE PIE PARA CAMILLAS CON MOTOR. CONSULTAR MODELOS.
 Commande à pied pour tables avec moteur. Voir modèles.
 Foot switch for tables equipped with motor. Check models.
 Fusschalter für elektrische Liegen. Modelle konsultieren.

R10MH-MP

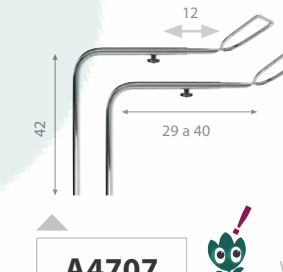

A4707

ADAPTADOR PARA 2 MANDOS DE CAMILLAS CON MOTOR. CONSULTAR MODELOS.
 Adaptateur 2 commandes pour tables avec moteur. Voir modèles.
 Connector 2 controls for tables equipped with motor. Check models.
 Adapter für 2 schalter bei elektrischen Liegen. Modelle konsultieren.

R10MH-T



A4471H

SISTEMA DE BLOQUEO PARA MOTORES. (MONTADO DE FÁBRICA). CONSULTAR MODELOS.
 Boîtier de verrouillage centralisé pour tables avec moteur (montage en usine). Voir modèles.
 Safety lock box (factory-installed) for tables equipped with motor. Check models.
 Sicherheitssperbox (Montage im Werk). Modelle konsultieren.



A4403C



A4403B

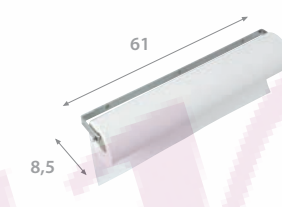

A4402C

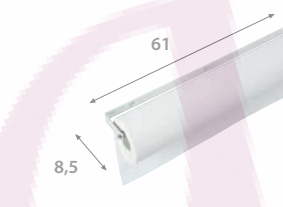

A4402B

ACCESORIOS PARA CAMILLAS PLEGABLES
 ACCESSOIRES POUR TABLES PLIANTES · ATTACHMENTS FOR PORTABLE TABLES
 ZUBEHÖR FÜR KOFFERMASSEGEBANK



A4450F/G 70x182/192 cm.



A4451F/G 70x182/192 cm.



A4473



A4435



A4440



A4461



A4430



A4417



ECOPOSTURAL PUEDE SUMINISTRARLE TAPIZADOS DE REPUESTO. CONSULTE CON NOSOTROS.
 ECOPOSTURAL PEUT FABRIQUER DES SELLERIES DE RECHANGE. CONSULTEZ-NOUS.
 REPLACEMENT UPHOLSTERY AVAILABLE UPON REQUEST. CONTACT ECOPOSTURAL.
 ECOPOSTURAL KANN IHNEN ERSATZ POLSTER ANBIETEN. ERKUNDIGEN SIE SICH BEI UNS.

A4411

A4418

A4445

A4439

A4415

A4438

A4465

A4433

A4464

A4437

A4436

A4463

A4446

A4413

A4406

A4448

A4427

A4407

A4454

A4434

A4414

A4462



Índice Alfabético

Index Alphabétique · Alphabetic Index · Alphabetischer Index

Table listing product codes (A, C, S, T) and page numbers for the alphabetical index.

Camillas Multifuncionales

Tables Multi-fonction · Multi-function Tables · Multifunktionelle Therapieliegen



Camillas Técnicas

Tables Techniques · Technical Tables · Therapieliegen für spezielle Techniken



Camillas Técnicas

Tables Techniques · Technical Tables · Therapieliegen für spezielle Techniken



Camillas y Sillones de Especialidades

Tables et Fauteuils pour les Spécialités · Speciality Tables and Chairs · Spezial-Liegen / Behandlungsstühle



Camillas y Sillones de Especialidades

Tables et Fauteuils pour les Spécialités · Speciality Tables and Chairs · Spezial-Liegen / Behandlungsstühle



Camillas de 3 Cuerpos

Tables 3 plans · 3 section tables · Therapieliegen mit 3 Segmente



mobilización para la salud

Camillas de 2 Cuerpos

Tables 2 plans · 2 section tables · Therapieliegen mit 2 Segmente



Camillas Plegables

Tables Pliantes · Portable Tables · Koffermassagebänke



Camillas Fijas

Tables Fixes · Stationary Tables · Stationäre Therapieliegen



Tabla de Inversión / Silla Multifuncional para Terapias

Table d'inversion / Chaise multi-fonction pour thérapies · Inversion table / Multi-function therapy chair · Inversions-Liege / Therapiestuhl



ecopostural para la salud

Taburetes y Sillas

Tabourets et Chaises - Stools and Chairs - Hocker / Stühle

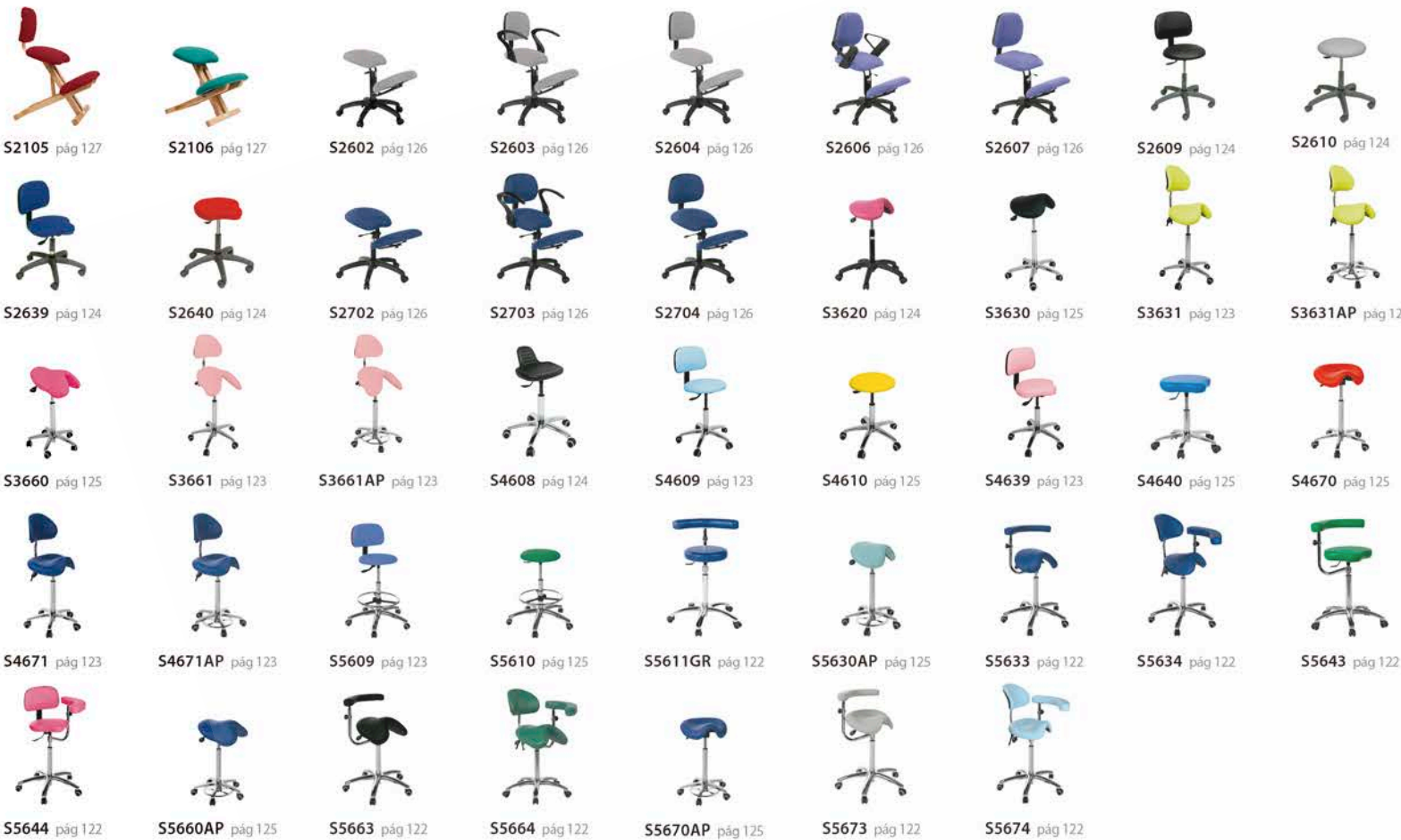

Accesorios

Accessoires - Accessories - Zubehör



Colores disponibles · Couleurs disponibles · Available colours · Verfügbare Farben

La reproducción fotográfica puede no ser totalmente exacta a la tonalidad de los colores naturales.

La reproduction photographique des couleurs peut ne pas être exacte à la couleur réelle des produits.

The photographic featuring of colours may not be totally accurate.

Die fotografische Abbildung kann von dem normalen Farbton etwas abweichen.

SIMBOLOGÍA DEL CATÁLOGO

EXPLICATIONS DES SYMBOLES - EXPLANATION OF SYMBOLS USED - ZEICHENERKLÄRUNG

SISTEMA DE ELEVACIÓN

Mécanismes pour le réglage de la hauteur - Height adjustment mechanisms - Regulierungssystem

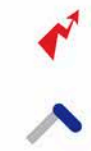

MOTOR ELÉCTRICO
Moteur électrique
Electric system
Elektrischer Motor



ACCIONAMIENTO PERIFÉRICO
Cadre périphérique
Side rails system
Rundumschaltung



ELEVADOR HIDRÁULICO
Pompe hydraulique
Hydraulic system
Hydraulische Höhenverstellung



MOTOR RÁPIDO
Moteur rapide
High-speed motor
Schneller Motor

TIPOS DE ELEVACIÓN

Élévation - Elevation - Höhenverstellungsvarianten

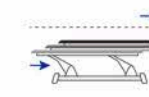

CON DESPLAZAMIENTO LATERAL
Déport latéral
Side misalignment
Mit seitlicher Verschiebung

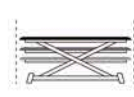

SIN DESPLAZAMIENTO LATERAL
Sans déport
Vertical alignment
Ohne seitliche Verschiebung

PESO MÁXIMO RECOMENDADO

Charge maximale recommandée - Recommended maximum weight
Maximalgewicht empfohlen



CAMILLA CON RODAMIENTO

Chassis avec roulements
With bearings
Therapieliegen mit Kugellager

GROSOR DE LA ESPUMA

Épaisseur de mousse - Foam thickness - Dicke des Schaumstoffes



GRADO DE FIRMEZA DE LA ESPUMA

Soutien de mousse - Foam firmness - Härtegrad des Schaumstoffes



SISTEMA DE REGULACIÓN DE LOS MÓDULOS

Réglage des plateaux - Sections adjustment - Regulierungssystem



SIMBOLOGÍA CAMILLAS FIJAS Y PLEGABLES

Symboles tables fixes & pliantes - Symbols used for stationary & portable tables
Zeichenerklärung von stationären und klappbaren Therapieliegen

